

Safety Instructions & Operator's Manual for

SNAPPER®

REAR ENGINE RIDING MOWER

SERIES 23

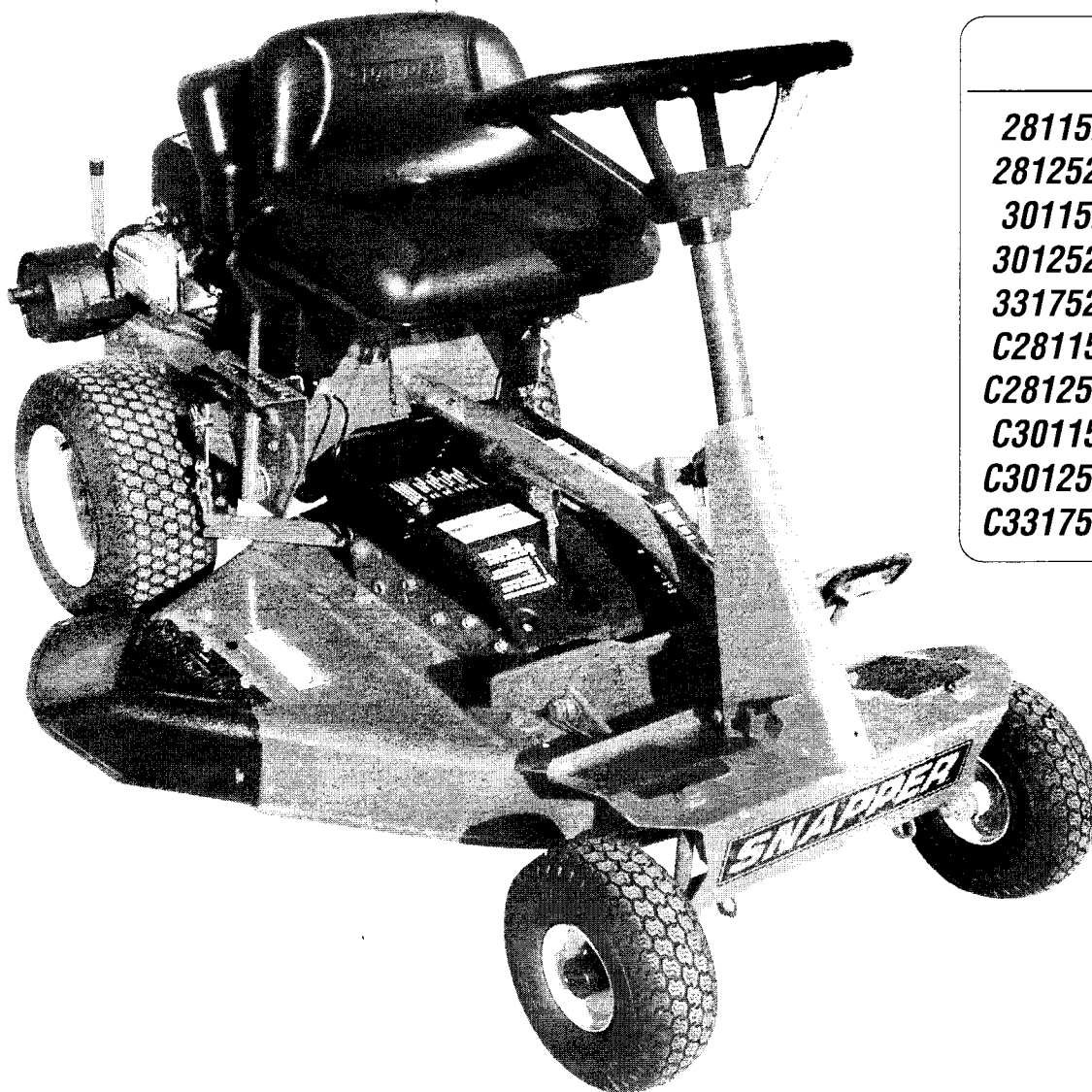

Models

2811523BV (7800102)
2812523BVE (7800104)
3011523BV (7800103)
3012523BVE (7800105)
3317523BVE (7800254)
C2811523BV (7800363)
C2812523BVE (7800365)
C3011523BV (7800364)
C3012523BVE (7800366)
C3317523BVE (7800368)

NOTE: Specifications are correct at time of printing and are subject to change without notice.

* Actual sustained engine power will likely be lower due to operating limitations and environmental factors. Please refer to 'Engine Power Rating Information' for further details.

Thank You for purchasing this quality-built Snapper product. We're pleased that you placed your confidence in the Snapper brand. When operated and maintained according to the instructions in this manual, your Snapper product will provide many years of dependable service.

This manual contains safety information to make you aware of the hazards and risks associated with the machine and how to avoid them. This machine is designed and intended only for finish cutting of established lawns and is not intended for any other purpose. It is important that you read and understand these instructions thoroughly before attempting to start or operate this equipment. Save these instructions for future reference.

PRODUCT REGISTRATION

IMPORTANT: KEEP THIS INFORMATION FOR YOUR PERSONAL RECORDS
(Complete the following information on your Snapper purchase)

Date of Purchase _____

Retailer _____

Retailer's Phone Number _____

Equipment

Model Number _____

Serial Number _____

Engine

Model _____ Type _____ Trim _____

It is very important that you register your purchase with Snapper to ensure warranty coverage. Please mail your product registration card to:



Snapper at P.O. Box 1379, McDonough, Georgia 30253.



Or you may register online at www.snapper.com.

You can contact us at our website, or if you would like to speak with a Customer Service Representative, call us at the Snapper Customer Relations Center at 1-800-935-2967. For faster service please have your Serial Number and Model Number available.

Table of Contents

Operator Safety	2
Important Operator Safety Instructions	2
Features and Controls	5
Operation	6
Pre-Start Checklist	6
Operator Seat Adjustment	6
Starting Engine	7
Engaging Mower Blade	9
Engaging Wheel Drive	9
Stopping Engine, Wheel Drive, Blade	10
Setting Park Brake	11
Cutting Height Adjustment	11
Reverse Lockout Mechanism	12
Maintenance	13
Service - After the First 5 Hours	13
Service - Every 25 Operating Hours	15
Service - Annually	18
Service - Every Two Years	18
Storage	18
Removing the Fuel Tank	18
Engine Adjustments and Repairs	19
Mower Deck and Component Adjustments	19
Rear Engine Rider Drive Components	22
Mower Blade Replacement	23
Mower Drive Belt Replacement	24
Battery	25
Snapper Rear Engine Rider Accessories	27
Service Schedule	28
Maintenance/Replacement Parts	29
Troubleshooting	30
Warranty	32

 **WARNING** 
 Battery posts, terminals and related accessories contain lead and lead compounds, chemicals known to the State of California to cause cancer and birth defects or other reproductive harm. Wash hands after handling.

 **WARNING** 
 Engine exhaust, some of its constituents, and certain vehicle components contain or emit chemicals known to the State of California to cause cancer or other reproductive harm.

Important Operator Safety Instructions

WARNING: This powerful cutting machine is capable of amputating hands and feet and can throw objects that can cause injury and damage! Failure to comply with the following SAFETY instructions could result in serious injury or death to the operator or other persons. The owner of the machine must understand these instructions and must allow only persons who understand these instructions to operate machine. Each person operating the machine must be of sound mind and body and must not be under the influence of any substance, which might impair vision, dexterity or judgment. If you have any questions pertaining to your machine which your dealer cannot answer to your satisfaction, call or write the Customer Service Department at SNAPPER, McDonough, Georgia 30253. Phone: (1-800-935-2967).

Protection for Children

Tragic accidents can occur if the operator is not alert to the presence of children. Children are often attracted to the machine and the mowing activity. Children who have been given rides in the past may suddenly appear in the mowing area for another ride and be run over or backed over by the machine. Never assume that children will remain where you last saw them.

1. KEEP children out of the mowing area and under the watchful care of a responsible adult other than the operator.
2. DO NOT allow children in yard when machine is operated (even with the blade OFF).
3. DO NOT allow children or others to ride on machine, attachments or towed equipment (even with the blades OFF). They may fall and be seriously injured.
4. DO NOT allow pre-teenage children to operate machine.
5. ALLOW only responsible adults & teenagers with mature judgment under close adult supervision to operate machine.
6. DO NOT operate blades in reverse. STOP BLADES. LOOK and SEE behind and down for children, pets and hazards before and while backing.
7. USE EXTRA CARE when approaching blind corners, shrubs, trees, or other objects that may obscure vision.

Protection against Tipovers

Slopes are a major factor related to loss-of-control and tip-over accidents, which can result in severe injury or death. All slopes require extra CAUTION. If you cannot back up the slope or if you feel uneasy on the slope, DO NOT mow it. Use extra care with grass catchers or other attachments; these affect the handling and the stability of the machine. Refer to the Slope Guide at the end of this manual.

1. DO NOT operate machine on slopes exceeding 15 degrees (27% grade).
2. Exercise EXTREME CAUTION on slopes above 10 degrees (18% grade). Turn blades OFF when traveling uphill. Use a slow speed and avoid sudden or sharp turns.
3. DO NOT operate machine back and forth across face of slopes. Operate up and down. Practice on slopes with blades off.
4. AVOID starting, stopping or turning on slopes. If machine stops going uphill or tires lose traction, turn blades OFF and back slowly straight down the slope.
5. STAY ALERT for holes and other hidden hazards. Tall grass can hide obstacles. Keep away from ditches, washouts, culverts, fences and protruding objects.

Protection against Tipovers

(Continued From Previous Column)

6. KEEP A SAFE DISTANCE (at least 3 feet) away from edge of ditches and other drop offs. The machine could turn over if an edge caves in.
7. Always begin forward motion slowly and with caution.
8. Use weights or a weighted load carrier in accordance with instructions supplied with a grass catcher. DO NOT operate machine on slopes exceeding 10 degrees (18% grade) when equipped with grass catcher.
9. DO NOT put your foot on the ground to try to stabilize the machine.
10. DO NOT operate machine on wet grass. Reduced traction could cause sliding.
11. Choose a low enough speed setting so that you will not have to stop or shift on a slope. Tires may lose traction on slopes even though the brakes are functioning properly.
12. DO NOT operate machine under any condition where traction, steering or stability is doubtful.
13. Always keep the machine in gear when going down slopes. DO NOT shift to neutral (or actuate hydro roll release) and coast downhill.

Preparation

1. Read, understand, and follow instructions and warnings in this manual and on the machine, engine and attachments. Know the controls and the proper use of the machine before starting.
2. Only mature, responsible persons shall operate the machine and only after proper instruction.
3. Data indicates that operators age 60 and above, are involved in a large percentage of mower-related injuries. These operators should evaluate their ability to operate the mower safely enough to protect themselves and others from serious injury.
4. Handle fuel with extra care. Fuels are flammable and vapors are explosive. Use only an approved fuel container. DO NOT remove fuel cap or add fuel with engine running. Add fuel outdoors only with engine stopped and cool. Clean spilled fuel from machine. DO NOT smoke.
5. Practice operation of machine with BLADES OFF to learn controls and develop skills.
6. Check the area to be mowed and remove all objects such as toys, wire, rocks, limbs and other objects that could cause injury if thrown by blade or interfere with mowing.



Important Operator Safety Instructions (Continued)



Protection against Tipovers

(Continued From Previous Column)

7. Keep people and pets out of mowing area. Immediately STOP blades, STOP engine, and STOP machine if anyone enters the area.
8. Check shields, deflectors, switches, blade controls and other safety devices frequently for proper operation and location.
9. Make sure all safety decals are clearly legible. Replace if damaged.
10. Protect yourself when mowing and wear safety glasses, a dust mask, long pants and substantial footwear.
11. Know how to STOP blades and engine quickly in preparation for emergencies.
12. Use extra care when loading or unloading the machine into a trailer or truck.
13. Check grass catcher components frequently for signs of wear or deterioration and replace as needed to prevent injury from thrown objects going through weak or worn spots.

Safe Handling of Gasoline

To avoid personal injury or property damage, use extreme care in handling gasoline. Gasoline is extremely flammable and the vapors are explosive.

1. Extinguish all cigarettes, cigars, pipes and other sources of ignition.
2. Use only an approved fuel container.
3. DO NOT remove fuel cap or add fuel with the engine running. Allow the engine to cool before refueling.
4. DO NOT refuel the machine indoors.
5. DO NOT store the machine or fuel container inside where there is an open flame, spark or pilot light such as on a water heater or other appliances.
6. DO NOT fill fuel containers inside a vehicle or on a truck or trailer bed with a plastic liner. Always place the containers on the ground away from the vehicle before filling.
7. Remove gas-powered equipment from the vehicle or trailer and refuel it on the ground. If this is not possible, then refuel equipment using a portable container, rather than a gasoline dispenser nozzle.
8. DO NOT start gas powered equipment in enclosed vehicles or trailers.
9. Keep the nozzle in contact with the rim of the fuel tank or container opening at all times until fueling is complete. DO NOT use a nozzle lock-open device
10. If fuel is spilled on clothing, change clothing immediately.
11. Never overfill a fuel tank. Replace fuel cap and tighten securely.

Operation

1. Mount and dismount machine from left side. Keep clear of discharge opening at all times.
2. Start engine from operator's seat, if possible. Make sure blades are OFF and parking brake is set.
3. DO NOT leave machine with engine running. STOP engine, STOP blades, SET brake, and Remove key before leaving operators position of any reason.
4. DO NOT operate machine unless properly seated with feet on feet rests or pedal(s).
5. STOP BLADES and ENGINE and make sure blades have stopped before removing grass catcher or unclogging mower to prevent loss of fingers or hand.
6. Blades must be OFF except when cutting grass. Set blades in highest position when mowing over rough ground.
7. Keep hands and feet away from rotating blades underneath deck. DO NOT place foot on ground while BLADES are ON or machine is in motion.
8. DO NOT operate machine without entire grass catcher or guards in place and working. DO NOT point discharge at people, passing cars, windows or doors.
9. Slow down before turning.
10. Watch out for traffic when near or crossing roadways.
11. STOP engine immediately after striking an obstruction. Inspect machine and repair damage before resuming operation.
12. Operate machine only in daylight or with good artificial light.
13. Move joystick (if equipped) SLOWLY to maintain control during speed and directional changes.
14. Exercise CAUTION when pulling loads. Limit loads to those you can safely control and attach loads to hitch plate as specified with SNAPPER attachment instructions.
15. On slopes, the weight of the towed equipment may cause loss of traction and loss of control. When towing, travel slowly and allow extra distance to stop.
16. DO NOT operate engine in enclosed areas. Engine exhaust gases contain carbon monoxide, a deadly poison.
17. DO NOT discharge material against a wall or obstruction. Material may ricochet back towards the operator.
18. Only use accessories approved by the manufacturer. See manufacturer's instructions for proper operation and installation of accessories.

! Important Operator Safety Instructions (Continued) !

Towing

1. Tow only with a machine that has a hitch designed for towing. DO NOT attach towed equipment except at the hitch point.
2. Follow the manufacturer's recommendation for weight limits for towed equipment and towing on slopes.
3. DO NOT allow children or others on towed equipment.
4. On slopes, the weight of the towed equipment may cause loss of traction and loss of control.
5. Travel slowly and allow extra distance to stop.

Maintenance

1. DO NOT store machine or fuel container inside where fumes may reach an open flame, spark or pilot light such as in a water heater, furnace, clothes dryer or other gas appliance. Allow engine to cool before storing machine in an enclosure. Store fuel container out of the reach of children in a well ventilated, unoccupied building.
2. Keep engine free of grass, leaves or excess grease to reduce fire hazard and engine overheating.
3. When draining fuel tank, drain fuel into an approved container outdoors and away from open flame.
4. Check brakes frequently; adjust, repair or replace as needed.
5. Keep all bolts, nuts and screws properly tight. Check that all cotter pins are in proper position.

Maintenance

(Continued From Previous Column)

6. Always provide adequate ventilation when running engine. Exhaust gases contain carbon monoxide, an odorless and deadly poison.
7. Disconnect negative (black) cable from battery before performing maintenance or service. Cranking engine could cause injury.
8. DO NOT work under machine without safety blocks.
9. Service engine and make adjustments only when engine is stopped. Remove spark plug wire(s) from spark plug(s) and secure wire(s) away from spark plug(s).
10. DO NOT change engine governor speed settings or overspeed engine.
11. Lubricate machine at intervals specified in manual to prevent controls from binding.
12. Mower blades are sharp and can cut. Wrap the blades or wear heavy leather gloves and use CAUTION when handling them.
13. DO NOT test for spark by grounding spark plug next to spark plug hole; spark plug could ignite gas exiting engine.
14. Have machine serviced by an authorized SNAPPER dealer at least once a year and have the dealer install any new safety devices.
15. Maintain or replace safety and instruction labels as necessary.
16. Use only genuine SNAPPER replacement parts to assure that original standards are maintained.

Features and Controls

IMPORTANT

The figures and illustrations in this manual are provided for reference only and may differ from your specific model. Contact your Snapper dealer if you have questions.

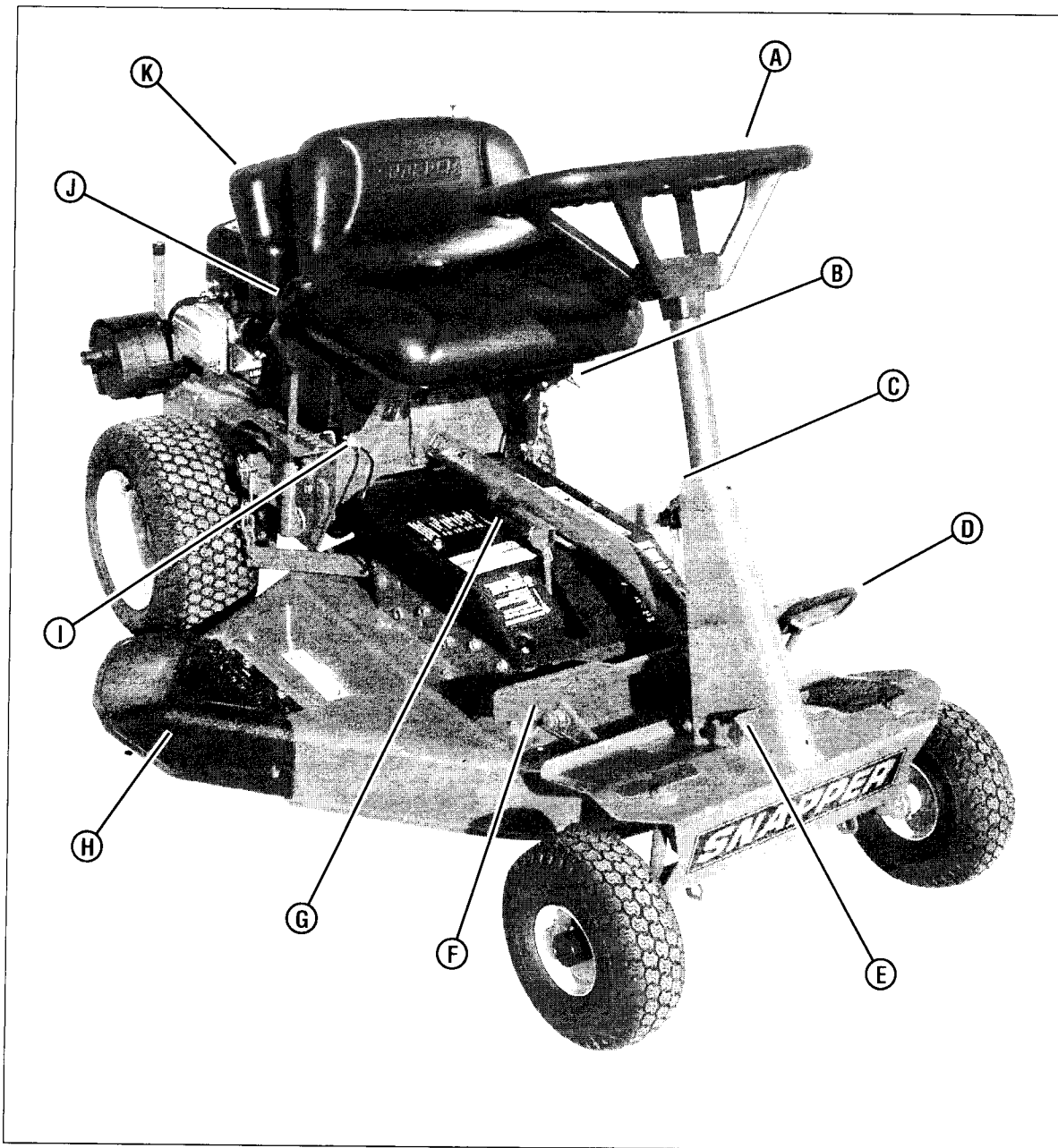

Features and Controls

Features and Controls

- | | | | |
|----|---|----|--------------------------|
| A. | Steering Wheel | F. | Blade Pedal |
| B. | Engine Speed Control (hidden from view) | G. | Blade Lever |
| C. | Ignition Switch | H. | Discharge Deflector |
| D. | Clutch/Brake Pedal | I. | Override Control |
| E. | Park Brake Latch | J. | Transmission Shift Lever |
| | | K. | Fuel Tank |

Operation

Pre-Start Check List

Make the following checks and perform the service required before each start-up:

1. Check the tire pressure; add or release air as needed to bring pressure to 12 PSI in front and 12 PSI in rear.
2. Check guards, deflectors and covers to make sure all are in place and securely tightened.
3. Check engine oil and add oil as needed to bring level up to the FULL mark (A, Figure 1). Refer to the engine manual for oil specifications.

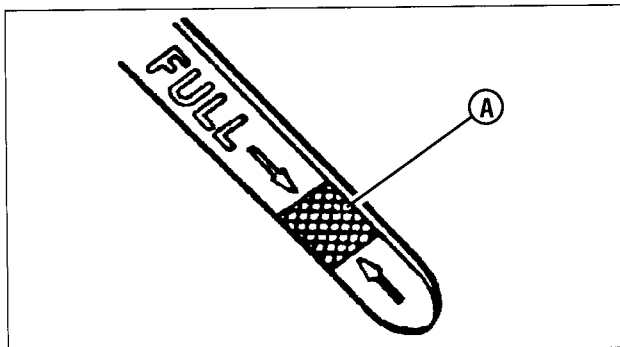

Figure 1: Engine oil 'Full' mark

4. Adjust the seat (A, Figure 3) as needed to the most comfortable position. Refer to the Section entitled "OPERATOR'S SEAT ADJUSTMENT".
5. Check the blade control to insure it works freely. If the blade pedals are depressed, the blade lever can be moved manually from "ON" to "OFF" to stop the blade.
6. Check the Reverse Lockout Mechanism. With the blade pedals depressed, the shift lever must not go into reverse.
7. Clean the exterior surfaces of the cutting deck and engine of any accumulation of dirt, grass, oil, etc. Keep the engine air intake screen and cooling fins clear at all times.
8. Add fuel to the fuel tank after pushing the Rear Engine Rider outside where fumes can dissipate. Make sure the fuel filler cap (A, Figure 2) is tight, and the vent (B) is open after refueling. Refer to the engine manual for fuel specifications.

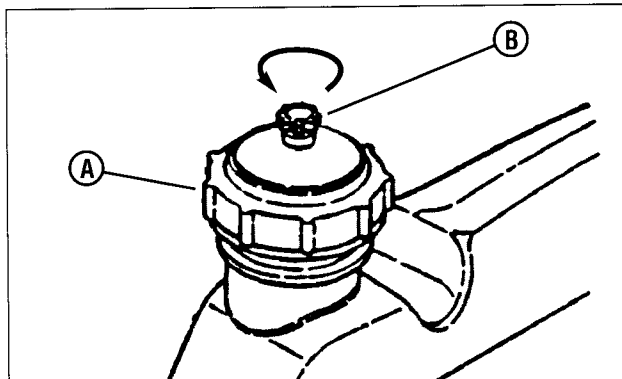

Figure 2: Fuel filler cap

Operator Seat Adjustment

1. With the engine stopped, loosen the two adjusting knobs (B, Figure 3) and move the seat to the desired position. After adjustment, tighten the knobs securely.

NOTE: If the seat does not move after loosening the knobs, it may be necessary to loosen the 5/16" patch lock screws or hex nuts (C) located at the rear of the seat.

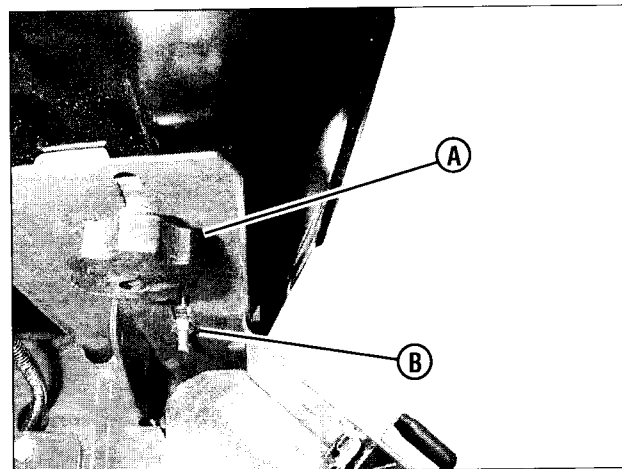
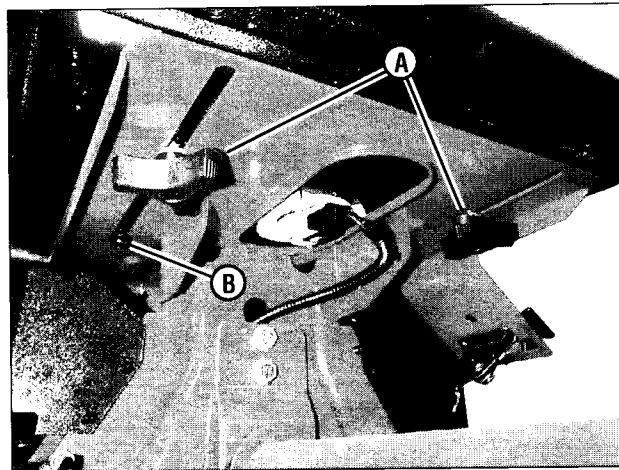

Figure 3: Operator seat adjustment

Operation (Continued)

Starting and Operation

Engine (Electric Start)

IMPORTANT: When the ignition key is turned to “START”, the engine will turn over, but will not start unless the Clutch/Brake pedal is pressed all the way down, and the Blade Lever is in the “OFF” position. The operator should be in the seat.

Start the engine as follows:

1. Open the vent (B, Figure 2) on the fuel filler cap (A) by turning counterclockwise.

IMPORTANT: Failure to open the vent on the fuel filler cap can cause the engine to stall.

2. Move the transmission shift lever to the (N) Neutral position. Refer to the section entitled “Wheel Drive”.

IMPORTANT: DO NOT start the engine with the transmission shift lever in a drive position.

WARNING

It is possible to start the engine with the transmission shift lever in a drive position. Follow starting instructions carefully.

2. Make certain the Blade Lever (A, Figure 4) is in the “OFF” position.

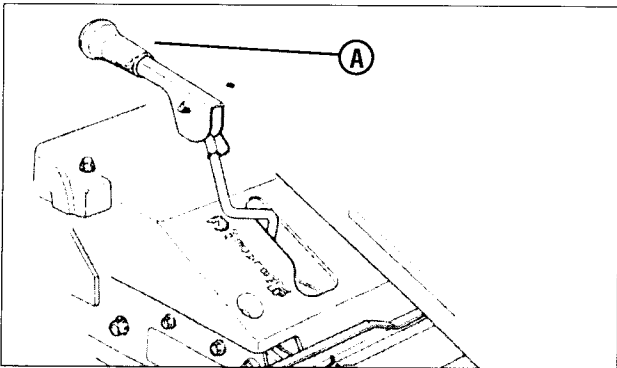

Figure 4: Blade lever (in 'Off' position)

3. Press the Clutch/Brake Pedal (A, Figure 5) all the way down and hold while starting the engine.
5. Move the engine speed control (A, Figure 6) to the choke position (B) to start a cold engine.
6. Turn the ignition key (A, Figure 7) to the “START” position until the engine starts.

NOTE: If after 5 seconds of cranking the engine does not start, release the key, make sure the Clutch/Brake Pedal is fully depressed, and attempt starting again after waiting for approximately 20 seconds.

7. After the engine starts, move the engine speed control to the “FAST” position and allow a brief warm-up until engine runs smooth.

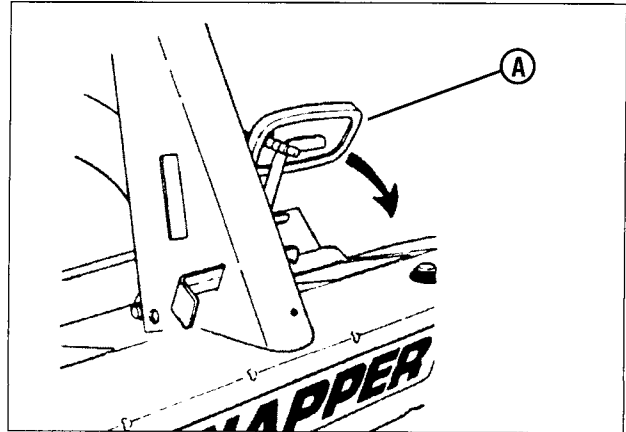

Figure 5: Engaging the clutch/brake pedal

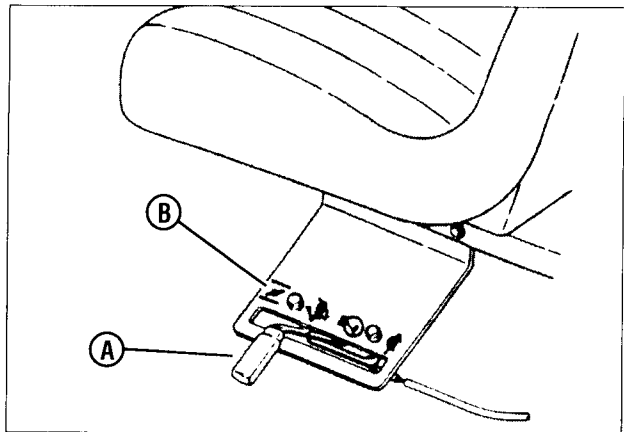

Figure 6: Engine speed control

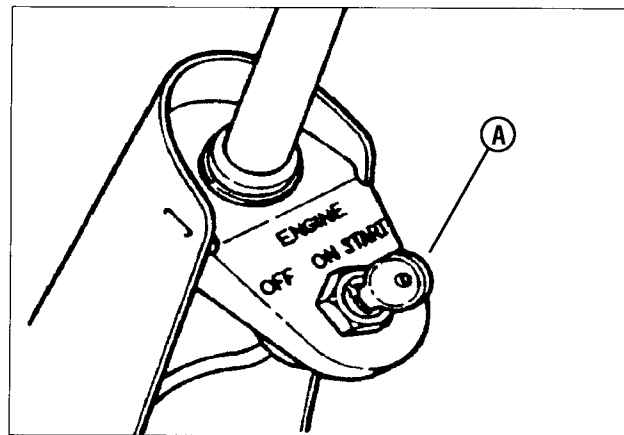

Figure 7: Ignition key

(Continued on Next Page)

Operation (Continued)

Starting and Operation (Continued)

Engine (Electric Start) (Continued)

- Should the battery be too weak to start the engine, refer to the Section entitled "Engine (Manual Start)" to manually start the electric start engines.
- On Model 3317523BVE and C3317523BVE, the engine is equipped with a fuel shut-off solenoid. If the battery is dead, the engine can be started with the recoil back-up starter if the engine speed control is in the choke position (HOT engine or COLD engine).

Engine (Manual Start)

IMPORTANT: When the key is turned to "ON", and the recoil handle is pulled, the engine will turn over, but will not start unless the Clutch/Brake Pedal is pressed all the way down with the Park Brake engaged, and the Blade Lever is in the "Off" position.

Start the engine as follows:

- Open the vent (B, Figure 2) on the fuel filler cap (A) by turning counterclockwise.

IMPORTANT: Failure to open the vent on the fuel filler cap can cause the engine to stall.

- Move the transmission shift lever to the (N) Neutral position. Refer to the section entitled "Wheel Drive".

IMPORTANT: DO NOT start the engine with the transmission shift lever in a drive position.



WARNING



It is possible to start the engine with the transmission shift lever in a drive position. Follow starting instructions carefully.

- Make certain the Blade Lever (A, Figure 4) is in the "OFF" position.
- Press the Clutch/Brake Pedal (A, Figure 8) all the way down, move the park brake latch (B) over, and release the clutch/brake pedal to set the park brake.

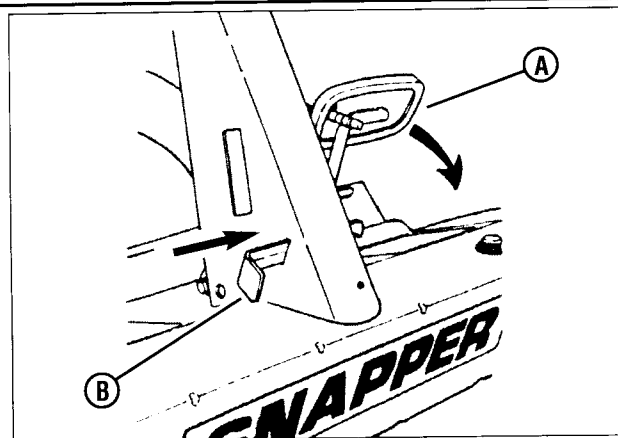

Figure 8: Setting the park brake

- Move the engine speed control (A, Figure 6) to the choke position (B) to start a cold engine.
- Turn the key (A, Figure 9) to the "ON" position.

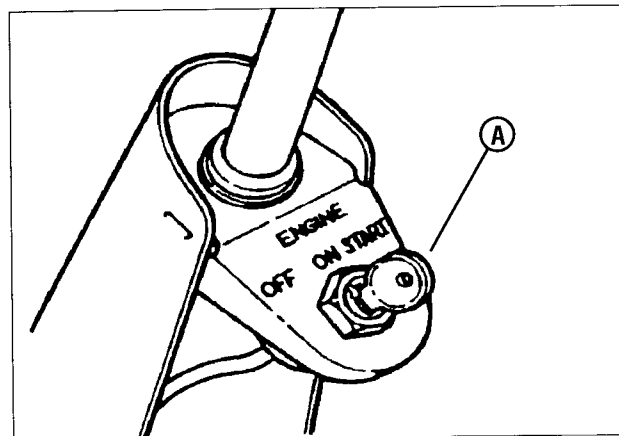

Figure 9: Key

- Pull the starter rope, located on the engine recoil, with a smooth, even motion until the engine starts.

NOTE: Always guide the starter rope back into the recoil housing. Never allow rope to snap back.

After the engine starts, move the engine speed control to the "FAST" position.

- Allow a brief warm-up until the engine runs smooth.

Operation (Continued)



WARNING



Once blade is disengaged, it should come to a complete stop in 3 seconds or less. If the blade continues to rotate after 3 seconds, the blade brake must be adjusted. Refer to Section "BLADE BRAKE ADJUSTMENT" for adjustment procedures or return machine to an authorized SNAPPER dealer for adjustment. DO NOT CONTINUE to operate machine until blade brake is adjusted and functioning properly.

Starting and Operation (Continued)

Mower Blade

1. With the engine running, move the engine speed control to the "FAST" position.
2. Move the blade lever (A, Figure 10) forward to the "ON" position, then depress the blade pedals (B) to hold the blade lever in the "ON" position.

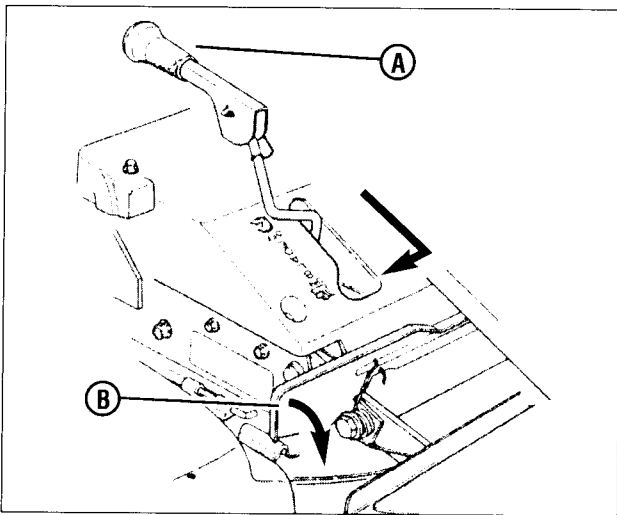

Figure 10: Engaging the mower blade

Wheel Drive

1. With the engine running, adjust the engine speed control to the "FAST" position.
2. Depress the clutch/brake pedal (A, Figure 11).
3. Place the transmission shift lever (A, Figure 12) into the first forward speed notch (B).
4. Release the clutch/brake pedal to begin forward motion.
5. During forward motion, the transmission shift lever may be placed in any desired forward speed without depressing the clutch/brake pedal.

NOTE: For best cutting results, move the transmission shift lever into a slow forward speed and the engine speed control to a fast position. This combination will allow the mower blades to lift the grass while cutting smoothly and evenly.



WARNING



DO NOT operate blades in reverse. STOP BLADES. LOOK and SEE behind and down for children, pets and hazards before and while backing.

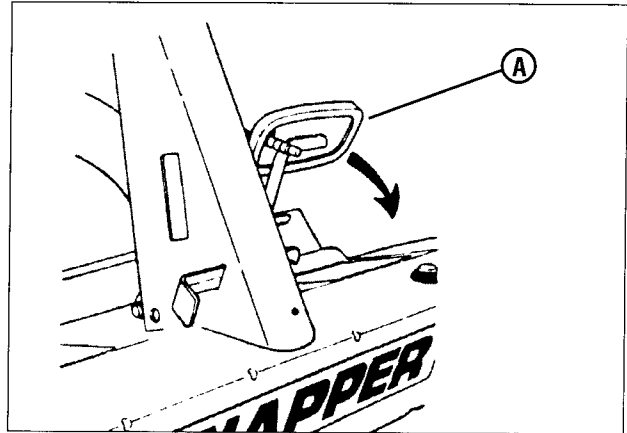

Figure 11: Engaging the clutch/brake pedal

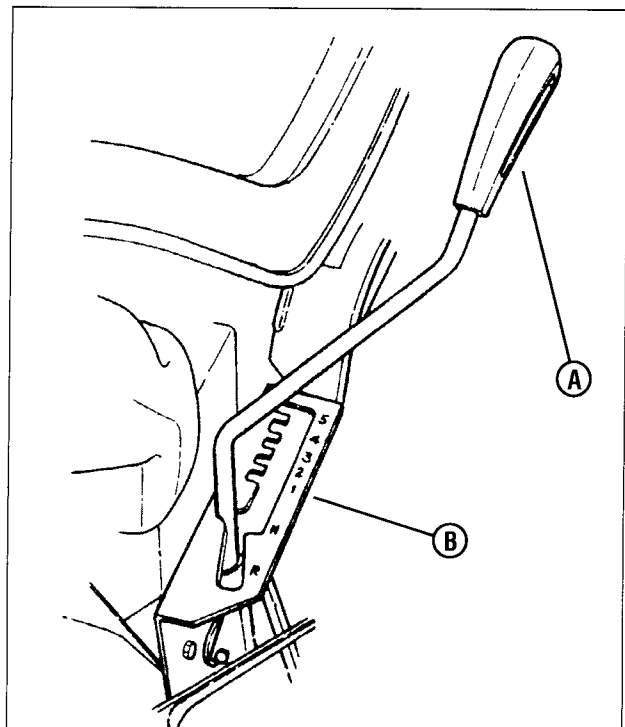

Figure 12: Transmission shift lever

Operation (Continued)



WARNING



DO NOT leave the machine with the engine running. STOP Blade. STOP engine. Shift to neutral and engage park brake. Remove key.

Stopping - Engine, Wheel Drive, Blade

Engine

1. Stop the engine by turning the key (A, Figure 13) to the "OFF" position.

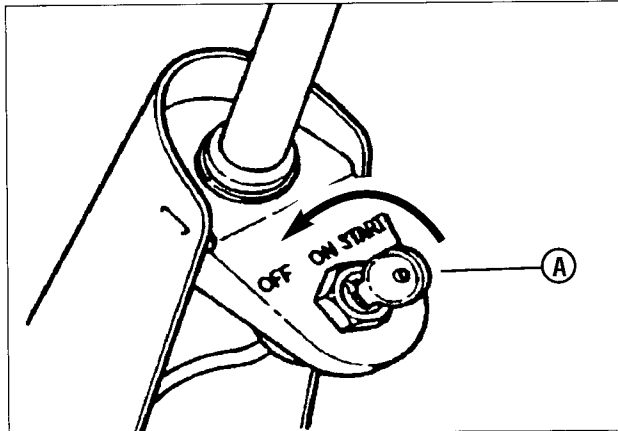

Figure 13: Turning key to 'Off'

Wheel Drive

1. Stop motion of the Rear Engine Rider by pushing the clutch/brake pedal (A, Figure 14) all the way down to apply the brake.

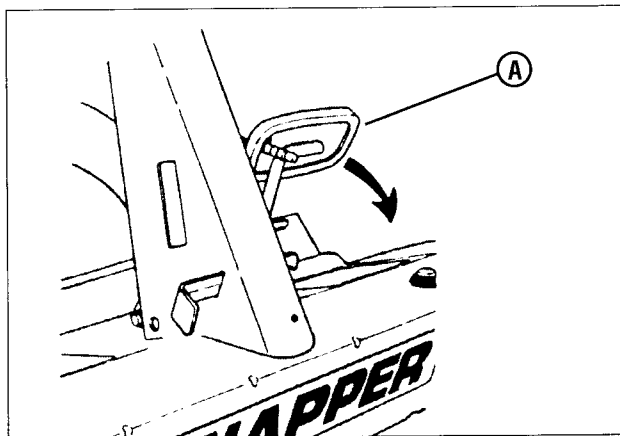

Figure 14: Engaging the clutch/brake pedal

Mower Blade

1. Stop the mower blade by releasing the blade pedals (A, Figure 15) or moving the blade lever (B) rearward to the "OFF" position.

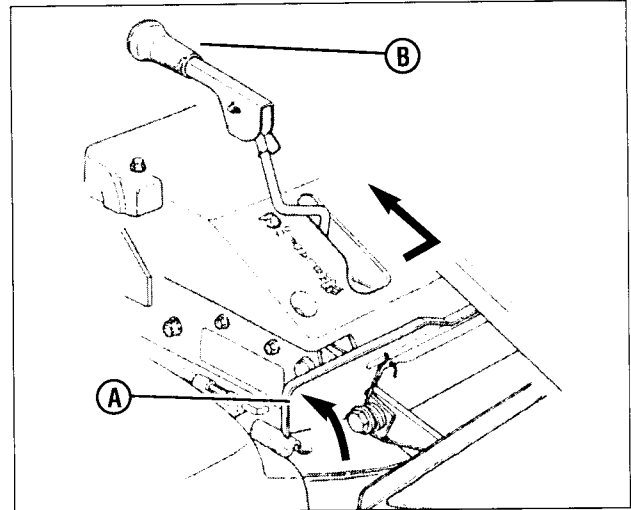

Figure 15: Stopping the mower blade



WARNING



Once blade is disengaged, it should come to a complete stop in 3 seconds or less. If the blade continues to rotate after 3 seconds, the blade brake must be adjusted. Refer to Section "BLADE BRAKE ADJUSTMENT" for adjustment procedures or return machine to an authorized SNAPPER dealer for adjustment. DO NOT CONTINUE to operate machine until blade brake is adjusted and functioning properly.

Operation (Continued)

Stopping - Engine, Wheel Drive, Blade (Continued)

Park Brake

1. To set the park brake, press the clutch/brake pedal (A, Figure 16) all the way down, slide the park brake latch (B) all the way in to the engaged position, and release the clutch/brake pedal. A detent in the park brake latch will keep the park brake engaged.

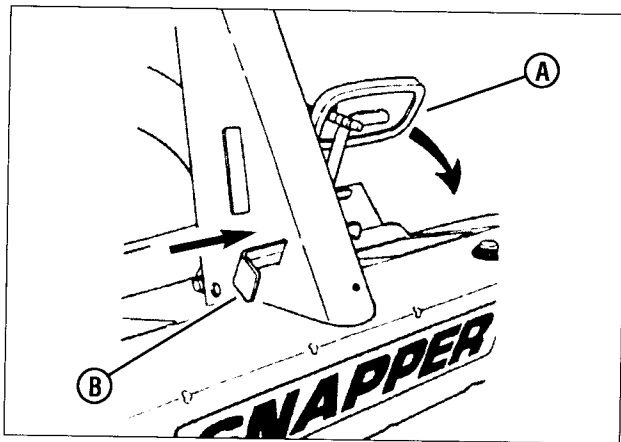

Figure 16: Setting the park brake

2. Release the park brake by pressing down firmly on the clutch/brake pedal (A, Figure 17). The park brake latch (B) is spring-loaded, and will slide back to the disengaged position unassisted.

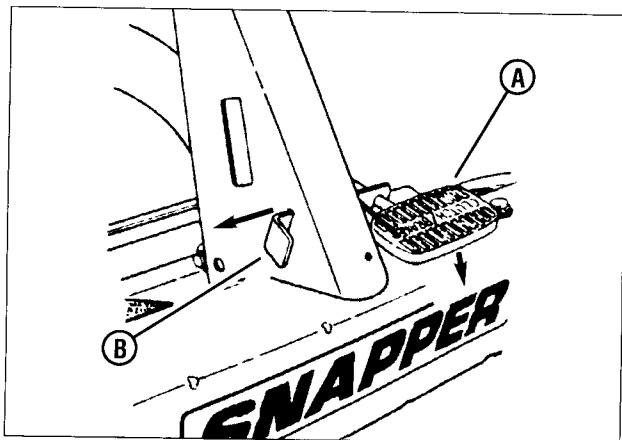

Figure 17: Releasing the park brake

Cutting Height Adjustment

1. Adjust the cutting height by raising or lowering the deck lift lever (A, Figure 18) into the desired height of cut notch (B).

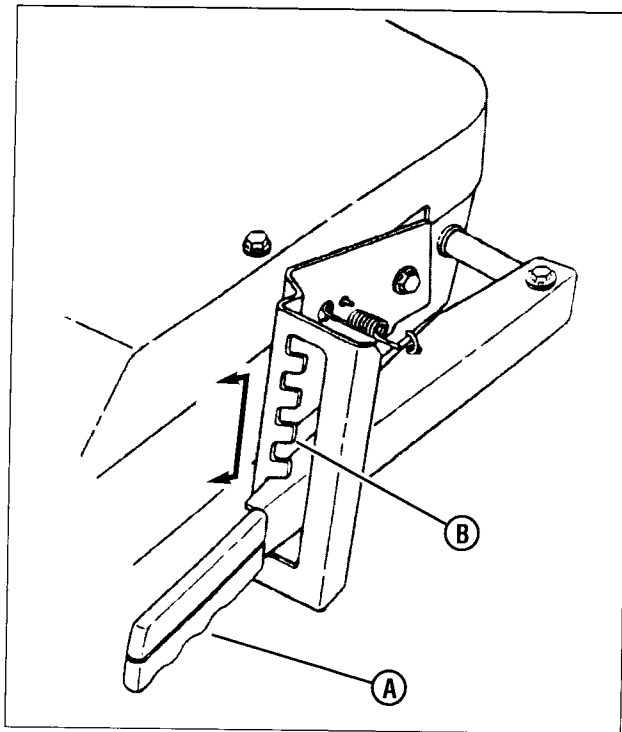

Figure 18: Cutting height adjustment

Operation

Operation (Continued)

Reverse Lockout Mechanism

Data indicates that tragic back-over accidents occur each year. These accidents usually involve unsupervised children. Many times these children have been given rides on the machine and have been trained to view this potentially dangerous piece of machinery as fun rather than being taught how to avoid danger.

This riding mower has a Reverse Lockout Mechanism. This mechanism prevents the mower from being shifted into reverse with the blade running. To shift into reverse you must first stop the blade by releasing the blade pedals and then shift to reverse. It is our recommendation that this mechanism remain functional and the operator of this equipment develop the habit of never backing up with the blade running. As the Safety Instructions Indicate, **DO NOT operate blades in reverse. STOP BLADES, LOOK AND SEE BEHIND AND DOWN for children, pets and hazards before and while backing.**

We realize that this could cause a change to your previous mowing method but we encourage you to adjust to this new system. Do not defeat the Reverse Lockout Mechanism.

If you operate your mower near roadways or use attachments that require quicker shifting to reverse, there is an override lever provided. This lever can be pushed and held before starting the blade and will allow reverse operation until the blade pedals are released, at which time the system will return to its Reverse Lockout mode. This feature should never be selected unless you are absolutely sure that no children or others are present in the mowing area and that all children are away and supervised by a responsible adult.

Reverse Lockout Mechanism Override

1. Stop the machine. Stop the blade.
2. Depress and hold the Override Lever.
3. Depress and hold the Blade Pedals. Release the Override Lever.
4. Move the blade lever forward to "ON" position.



WARNING



LOOK and SEE behind and down for children, pets and hazards before and while backing.

IMPORTANT: DO NOT use the Reverse Lockout Mechanism Override as the normal operating mode. To return to the Reverse Lockout Mechanism mode, release blade pedals to turn blade off. The Override will reset to Reverse Lockout. Check the Reverse Lockout Mechanism frequently for proper function. With the blade pedals depressed, the shift lever must not go into reverse. DO NOT operate machine if Reverse Lockout Mechanism is not functioning properly. Contact your local Snapper dealer for assistance.



DANGER



LOOK and SEE behind and down for children, pets and hazards before and while backing.
BLADES must be turned off before backing machine.
DO NOT allow children on machine (even with blades off) or in yard when mowing.



Amputation hazard



- Do not mow when children or others are around.
- Do not carry riders (especially children) even with the blades off. They may fall off or return for another ride when you are not expecting it.
- Look down and behind before and while backing.

Maintenance



WARNING



DO NOT attempt any adjustments, maintenance, service or repairs with the engine running. STOP engine. STOP blade. Engage parking brake. Remove key. Remove spark plug wire from spark plug and secure away from plug. Engine and components are HOT. Avoid serious burns, allow all parts to cool before working on machine. Fuel Filler Cap and vent must be closed securely to prevent fuel spillage.

Introduction

To retain the quality of the Rear Engine Rider, use genuine SNAPPER replacement parts only. Contact a local SNAPPER dealer for parts and service assistance. For the correct part or information for a particular Rear Engine Riding Mower, always mention the model and serial number. SNAPPER recommends returning the Rear Engine Rider to an authorized SNAPPER dealer annually for inspection and addition of any new devices, which might upgrade the safety of the Rear Engine Rider. For the nearest SNAPPER dealer in your area, check the yellow pages under the heading LAWN MOWERS. For engine parts and service, look for the engine manufacturer's dealers under the heading, ENGINES - gasoline.

Service - After the First 5 Hours

Routine maintenance is important to the performance and life of your Rear Engine Rider. Service performed properly and at the recommended interval is essential. Refer to the section entitled "MAINTENANCE SCHEDULE" in this manual and in the Engine Owner's Manual. Carefully complete all of the recommended service procedures.

Change Engine Oil

1. Place bricks or wooden blocks under the front wheels to lower the rear of the engine.
2. Loosen or remove the oil fill cap on the engine.
3. Place a 2 quart minimum capacity container under the end of the oil drain (Figure 19).
4. Remove or open the oil drain plug (A or B, Figure 19), depending upon the type of oil drain plug the engine is equipped with.

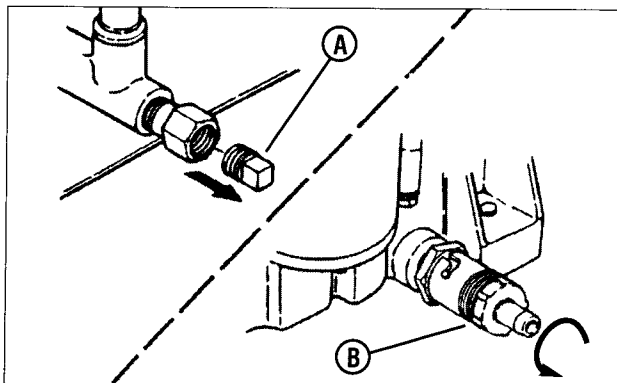

Figure 19: Oil drain plugs

5. After all the oil has drained, replace or close the drain plug, and wipe up any oil that may have spilled. Dispose of used oil properly.
6. Fill the engine crankcase with new oil. Refer to the engine manual for oil specifications.
7. Change the oil filter on engines equipped with oil filters at every oil change. Refer to the engine manual for service instructions.

Service Engine Air Cleaner

The engine is equipped with a dual element air cleaner. Both the foam pre-cleaner and cartridge require service. Refer to the Engine Manual for recommended service procedures.

Check Mower Blade

1. Follow the WARNING statement found on this page.
2. Check the fuel level in the tank. If over 3/4 full, remove the tank. Refer to the section entitled "REMOVING FUEL TANK". If 3/4 or less, proceed to the next step.
3. Carefully stand the Rear Engine Rider on the rear bumper.



DANGER



Remove the battery if the Rear Engine Rider will be left standing on the rear bumper for longer than 2 hours. Refer to the section entitled "BATTERY REMOVAL". DO NOT use a cutting blade that shows signs of excessive wear or damage on the Rear Engine Rider. Refer to the section entitled "MOWER BLADE REPLACEMENT" for proper blade inspection and service procedures.

4. Check the torque of the blade mounting bolts (A, Figure 20). As necessary, torque to 30 to 40 ft. lbs.
5. Check the blade for sharpness, wear and damage. Refer to the section entitled "BLADE WEAR LIMITS".

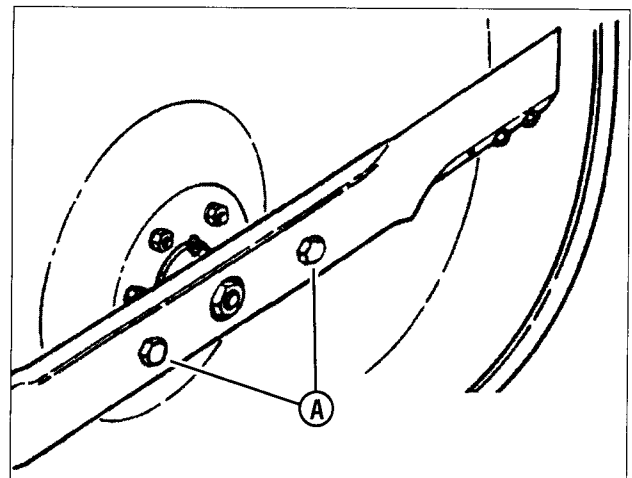

Figure 20: Checking blade bolt torque

6. Check the blade for straightness. Refer to the section entitled "ADJUSTING MOWER BLADE".

Maintenance (Continued)



WARNING



DO NOT attempt any adjustments, maintenance, service or repairs with the engine running. STOP engine. STOP blade. Engage parking brake. Remove key. Remove spark plug wire from spark plug and secure away from plug. Engine and components are HOT. Avoid serious burns, allow all parts to cool before working on machine. Fuel Filler Cap and vent must be closed securely to prevent fuel spillage.

Service - After the First 5 Hours (Continued)

Check the Blade Drive Belt

The blade drive consists of a single belt from the engine to the deck. Inspect for signs of deterioration and proper tension.

1. Lower the deck to the lowest setting.
2. Remove the four self-tapping screws (A, Figure 21), two on each side of mower drive belt cover (B).
3. Slide the cover back and rotate out on the left side of the mower deck.

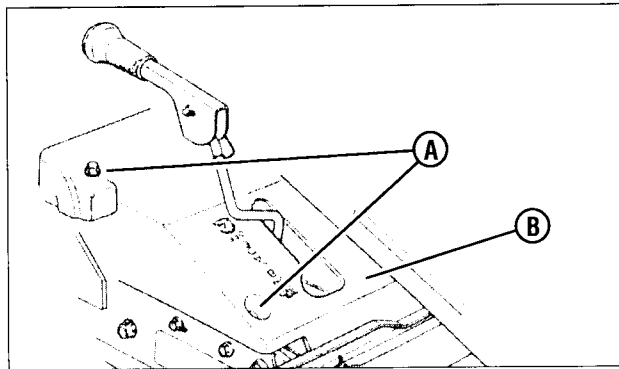

Figure 21: Removing the drive belt cover

4. Raise the deck to the 3rd height of cut position (middle notch). With the engine "OFF", move the blade lever back to the "ON" position and depress the blade pedals.
5. 28" and 30" Decks *: Measure the belt spacing at the idler pulley (A, Figure 22). The belt spacing (B) should be 1-1/4" but no less than 1". If the measurement is less than 1", the belt tension should be adjusted. Refer to the section entitled "BLADE DRIVE BELT ADJUSTMENT".

* **IMPORTANT:** The blade drive belt on 33" decks does not require tension adjustment. If the belt becomes worn or slack it must be replaced. Refer to the section entitled "BLADE DRIVE BELT REPLACEMENT".

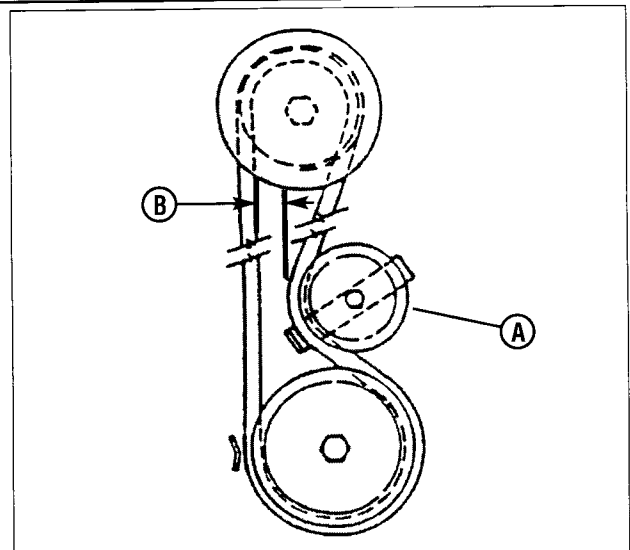

Figure 22: Measuring the belt spacing



WARNING



The following procedure requires the engine and blades to be operated. Exercise extreme caution. Clear area of loose parts & tools first. Only operate blades when seated in the operator's seat.

Blade Brake

1. Check the blade brake for proper function. The blade should stop rotating in 3 seconds or less after moving the blade control lever to the "OFF" position or after releasing the blade pedals.



WARNING



Blades must stop rotating in 3 seconds or less after the blade has been turned off. DO NOT operate machine until blade brake has been adjusted and functioning properly.

2. If the blade continues to rotate longer than 3 seconds do not operate the machine. Refer to the section entitled "BLADE BRAKE ADJUSTMENT", or contact your SNAPPER dealer for assistance.

Service Brake / Park Brake

1. Check the machine brake for proper function:
 - Engage the park brake, and push the machine. The rear tires should skid.
 - Drive the machine forward and apply the brake. The machine should come to a complete stop in less than 5 ft.
2. If the brakes are not functioning properly, brake adjustment must be completed before operating the machine. Refer to the section entitled "SERVICE BRAKE - PARK BRAKE ADJUSTMENT".

Maintenance (Continued)

Service - After the First 5 Hours (Continued)

Safety Interlock System Checks

Perform the following interlock system checks periodically during the operating season. Contact your authorized Snapper dealer if you have questions.



WARNING



DO NOT operate machine if any safety interlock or safety device is not in place and functioning properly. DO NOT attempt to defeat, modify or remove any safety device.

Engine must not start if:

1. The Clutch/Brake Pedal is not fully depressed OR,
2. The Blade Control is in the "ON" (blades engaged) position.

Engine should start if:

1. The Blade Control is in the "OFF" (blades disengaged) position AND,
2. The Clutch/Brake Pedal is fully depressed.

Engine and blades must stop if:

1. The operator rises off of seat with Blade Control in "ON" (blades engaged) position OR,
2. The operator rises off of seat with Clutch/Brake Pedal not fully depressed.

Reverse Lockout Mechanism

Check the function of the Reverse Lockout Mechanism with the engine off.

1. Depress and hold the blade pedals.
2. Depress and hold the clutch/brake pedal.
3. With Steps 1 and 2 performed, the shift lever must not go into reverse.



WARNING



DO NOT operate machine if Reverse Lockout Mechanism is not functioning properly. Contact your SNAPPER dealer immediately for assistance.

Lubrication – Grease Fittings

The following components on the Rear Engine Rider are equipped with grease fittings and require periodic lubrication. Apply General Purpose grease (NLGI No.2) with a grease gun.

1. Front Wheel Bearings. Refer to the section entitled "FRONT WHEEL BEARINGS – LUBRICATION".
2. Rear Axle Bearing. Refer to the section entitled "REAR AXLE BEARING – LUBRICATION".
3. Mower Blade Spindle. Refer to the section entitled "MOWER BLADE SPINDLE – LUBRICATION".
4. Shift Lever. Refer to the section entitled "SHIFT LEVER – LUBRICATION".

Service - Every 25 Operating Hours

Perform all service required after the first 5 hours of operation. Refer to the section entitled "SERVICE – AFTER 5 HOURS".

Check Engine

1. Change the engine oil. Refer to the section entitled "CHANGE ENGINE OIL". Refer to the engine manual for oil specifications.
2. Change the air filter:
 - Pull up and rotate the air cleaner latch (A, Figure 23) to remove the air cleaner cover (B).

IMPORTANT: When the cover is removed, you are viewing the carburetor side of the air filter, which will appear clean. Remove the filter and pre-cleaner for inspection.

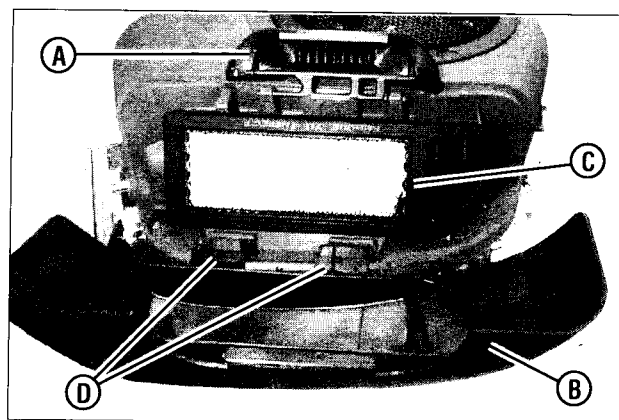

Figure 23: Opening the engine air cleaner cover
(Briggs engine shown)

- Remove the air cleaner (C).
- Remove and clean the engine air pre-cleaner (located behind the air cleaner). Refer to the engine manual for cleaning and service instructions.
- Install the pre-cleaner and replace the air cleaner per the engine manual.
- Reinstall the air cleaner cover. Engage the latch over the cover and rotate and push down to lock.

IMPORTANT: The tabs (D) on the air cleaner cover must be completely inserted into the corresponding slots in the engine cover, or the compartment will not be completely sealed to prevent debris from entering into the carburetor.

Maintenance (Continued)



WARNING



DO NOT attempt any adjustments, maintenance, service or repairs with the engine running. STOP engine. STOP blade. Engage parking brake. Remove key. Remove spark plug wire from spark plug and secure away from plug. Engine and components are HOT. Avoid serious burns, allow all parts to cool before working on machine. Fuel Filler Cap and vent must be closed securely to prevent fuel spillage.

Service - Every 25 Operating Hours (Continued)

Battery Fluid Level

1. Remove the battery. Refer to the section entitled "BATTERY REMOVAL".
2. Remove the battery caps. Check the fluid level.
3. Add water only to bring fluid to proper level. DO NOT OVERFILL.
4. Reinstall the battery. Refer to the section entitled "BATTERY INSTALLATION".

Mower Deck Levelness

Check the mower deck for proper level. Adjust as required. Refer to the section entitled "MOWER DECK ADJUSTMENT - LEVELNESS".

Clean Mower Deck

1. Follow the WARNING statement found on this page.
2. Check the fuel level in the tank. If over 3/4 full, remove the tank. Refer to the section entitled "REMOVING FUEL TANK". If 3/4 or less, proceed to the next step.
3. Carefully stand the Rear Engine Rider on the rear bumper.
4. Clean the underside of the mower deck, removing all accumulation of grass clippings and debris.
5. Clean the top of the deck, removing all grass clippings and debris.

Mower Blade Spindle - Lubrication

1. Follow the WARNING statement found on this page.
2. Check the fuel level in tank. If over 3/4 full, remove the tank. Refer to the section entitled "FUEL TANK REMOVAL". If 3/4 or less, proceed to the next step.
3. Carefully stand the Rear Engine Rider on the rear bumper.
4. Lubricate the spindle grease fitting (A, Figure 24) with three shots of general purpose grease from a grease gun.

IMPORTANT: If the Rear Engine Rider will be on its rear bumper for longer than two hours, remove the battery. Refer to the section entitled "BATTERY REMOVAL".

Mower Deck Linkage - Lubrication

Lubricate all mower deck linkage pivot points with a light coat of motor oil.

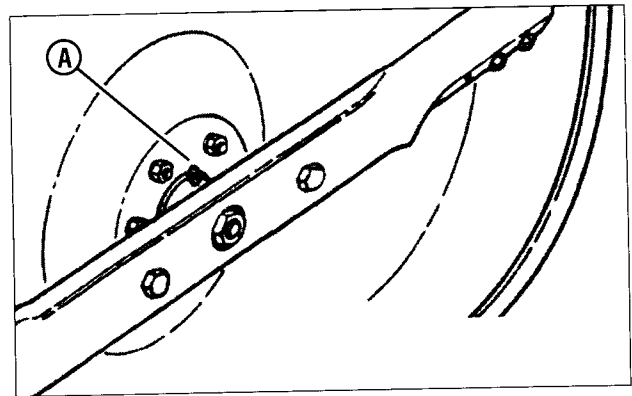

Figure 24: Mower blade spindle grease fitting

Front Wheel Bearing - Lubrication

Lubricate the front wheel grease fittings (A, Figure 25) with five shots of general purpose grease, from a grease gun.

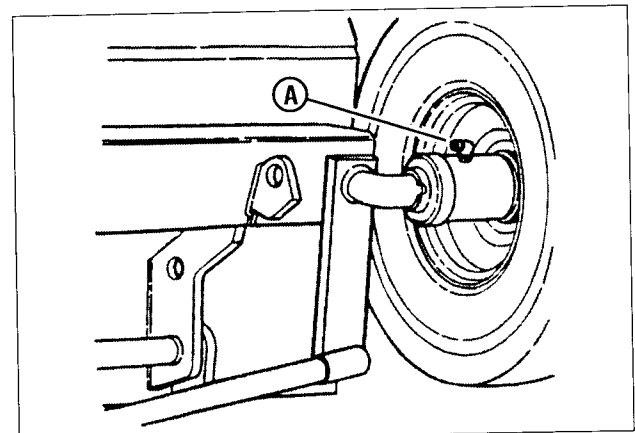

Figure 25: Front wheel grease fitting

Shift Lever - Lubrication

Lubricate the shift lever grease fitting (A, Figure 26) with two shots of general purpose grease from a grease gun.

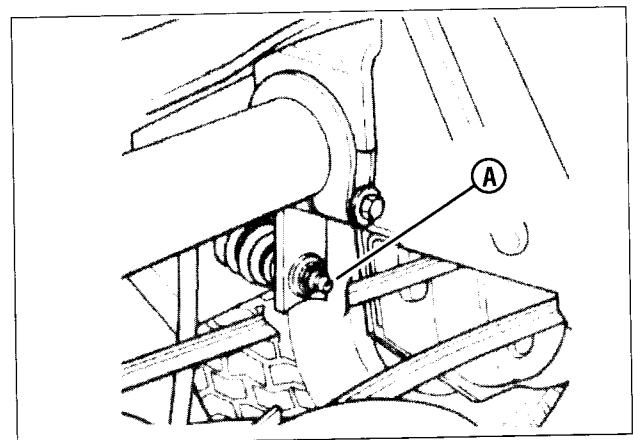

Figure 26: Shift lever grease fitting

Maintenance (Continued)



WARNING



DO NOT attempt any adjustments, maintenance, service or repairs with the engine running. STOP engine. STOP blade. Engage parking brake. Remove key. Remove spark plug wire from spark plug and secure away from plug. Engine and components are HOT. Avoid serious burns, allow all parts to cool before working on machine. Fuel Filler Cap and vent must be closed securely to prevent fuel spillage.

Service - Every 25 Operating Hours (Continued)

Rear Axle Bearing - Lubrication

1. The grease fitting (A, Figure 27) on the left rear axle bearing requires three shots of general purpose grease from grease gun.
2. The right rear axle bearing is lubricated by the differential lubricant and requires no grease.

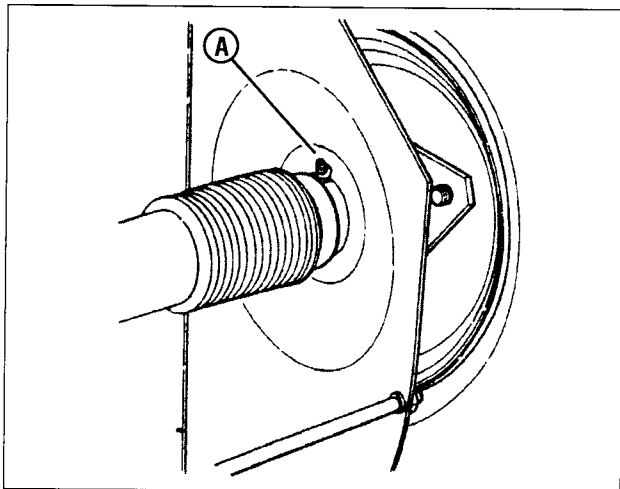

Figure 27: Rear axle grease fitting

Differential / Chain Case - Lubrication

1. Stand the rear engine rider on its rear bumper and check the fill/level plug (A, Figure 28) on the differential (B) for cracks and wear. Replace the fill/level plug if signs of wear are visible.

IMPORTANT: If the Rear Engine Rider will be on its rear bumper for longer than two hours, remove the battery. Refer to the section entitled "BATTERY REMOVAL".

2. To check lubricant, remove the fill/level plug and visually inspect for lubricant on the internal parts of the differential. If no lubricant is visible on the internal parts of the differential, add transmission grease as needed.

IMPORTANT: Overfilling of the differential with lubricant will cause lubricant to leak onto drive components of the Rear Engine Rider.

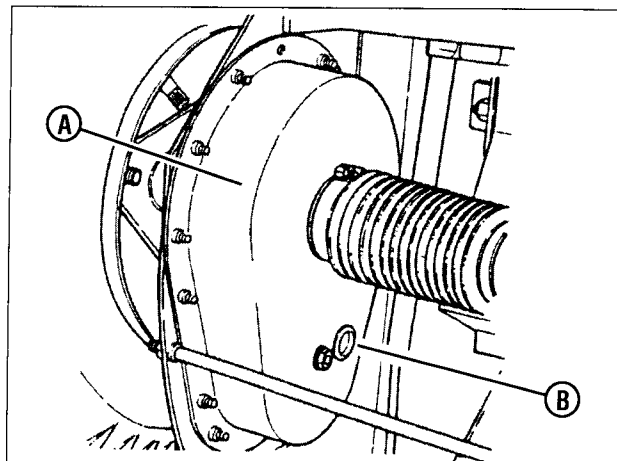

Figure 28: Differential lubricant check

3. Check the fill/level plug (A, Figure 29) on the chain case (B) for damage. If signs of wear or cracks are visible, replace with a new plug.
4. To check lubricant in the chain case, remove the fill/level plug and look for lubricant on the internal components of the chain case. If no lubricant is visible, add SNAPPER transmission grease as needed.

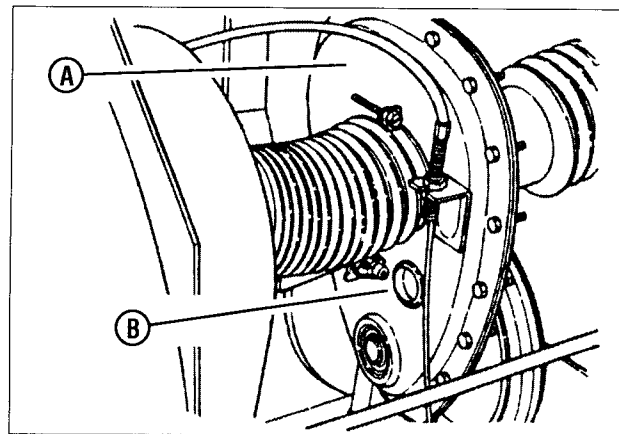

Figure 29: Chain case lubricant check

Engine Service

Check the MAINTENANCE SCHEDULE section of the Engine Manual for additional engine service.

Maintenance (Continued)



WARNING



DO NOT attempt any adjustments, maintenance, service or repairs with the engine running. STOP engine. STOP blade. Engage parking brake. Remove key. Remove spark plug wire from spark plug and secure away from plug. Engine and components are HOT. Avoid serious burns, allow all parts to cool before working on machine. Fuel Filler Cap and vent must be closed securely to prevent fuel spillage.

Service - Annually

Engine

Perform all maintenance as specified in "MAINTENANCE SCHEDULE" Section of this manual.

Fuel Filter

IMPORTANT: Service the fuel filter on a COLD ENGINE ONLY!

IMPORTANT: To stop the flow of fuel, the fuel tank (C, Figure 30) may be removed from the bracket and set on the floor so the fuel level will be below the filter. Refer to the section entitled "REMOVING FUEL TANK".

1. Remove the hose clamps (B, Figure 30) from the fuel filter (A).
2. Remove the fuel lines from filter. Discard the filter.
3. Install a new fuel filter.
4. Reinstall the fuel tank into the bracket (if removed).
5. Carefully reinstall the fuel clamps.
6. Check the fuel system for leaks.

Every Two Years

In addition to regular maintenance, the following components of the Rear Engine Rider should be carefully inspected every two years for wear or damage.

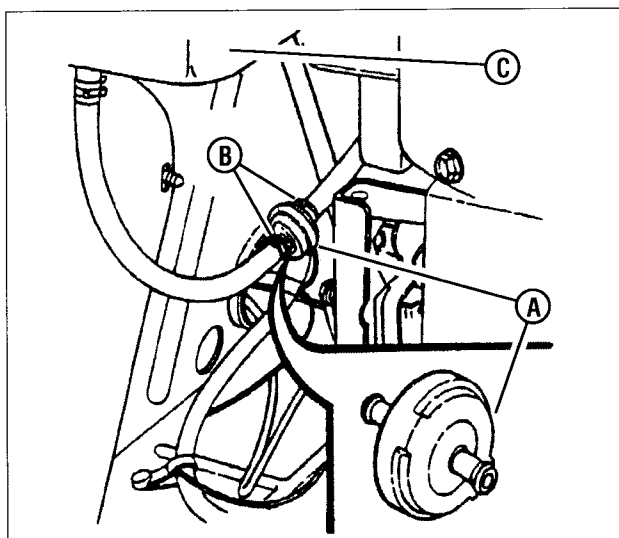

Figure 30: Replacing the fuel filter

1. All bushings and pivot areas.
2. Check both front wheel king pins.
3. Transmission shift lever and detent.
4. Clutch disc.
5. Clutch yoke.
6. Mower deck linkage and pivot areas.

Replace worn or damaged parts with genuine SNAPPER replacement parts available from an authorized SNAPPER dealer.

Storage (Out of Season)

If desired, the Rear Engine Rider can be stored on the rear bumper. Perform the following procedures to insure the Rear Engine Rider will operate properly when taken out of storage.

1. Thoroughly clean the Rear Engine Rider by removing all grass clippings and debris.
2. Perform maintenance and lubrication as required.
3. Drain the fuel from the fuel tank.
4. Start the engine and allow it to run until the engine runs out of fuel. This allows the carburetor and fuel system to remain clean during storage.
5. Remove the battery. Refer to the section entitled "BATTERY STORAGE".
6. Close the vent on the fuel filler cap.
7. Carefully stand the Rear Engine Rider on its rear bumper in the desired location for storage.

Removing the Fuel Tank

NOTE: Before removing the fuel tank from the rear engine rider, move the rider outdoors where fumes can easily dissipate.

1. From the left side of the machine, pull the fuel tank (A, Figure 31) straight up and away from the fuel tank bracket (B).
2. Holding the fuel tank, remove the fuel filler cap (C) and pour any remaining fuel into an approved container.

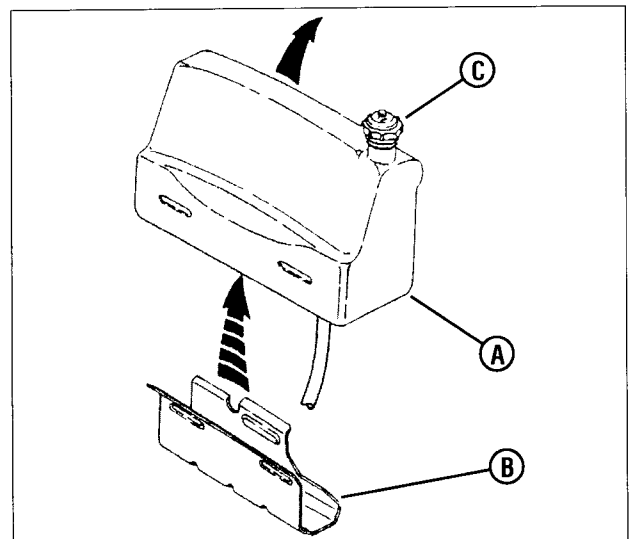

Figure 31: Removing the fuel tank

Maintenance (Continued)



WARNING



DO NOT attempt any adjustments, maintenance, service or repairs with the engine running. STOP engine. STOP blade. Engage parking brake. Remove key. Remove spark plug wire from spark plug and secure away from plug. Engine and components are HOT. Avoid serious burns, allow all parts to cool before working on machine. Fuel Filler Cap and vent must be closed securely to prevent fuel spillage.



WARNING



DO NOT operate machine until blade brake is adjusted and functioning properly. If blade stop time can not be achieved with the adjustment procedure described above, take machine immediately to an authorized Snapper dealer.

Engine Adjustments and Repair

Refer to the engine manual for those adjustments and/or repairs that can be made by the owner.

Mower Deck and Component Adjustments

The following mower deck and component adjustments and repairs can be made by the owner. However, if there is difficulty in achieving these adjustments and repairs, it is recommended that these repairs be made by an authorized SNAPPER dealer.

Blade Brake Adjustment

The automatic Blade Brake should stop the blades within 3 seconds any time the blades are disengaged by moving the blade lever to the "OFF" position or by releasing the Blade Pedals. If the blades take longer than 3 seconds to stop, perform the following measurement and adjustment.

1. With the blade engagement lever disengaged, measure the distance between the front of the blade lever (A, Figure 32) and the edge of the latch plate (B). The dimension (C) should be 3" to 3-1/4" clearance between the lever and the edge of the plate. If the dimension is incorrect go to step 2.
2. Remove the belt cover. Refer to the section entitled "BLADE BELT COVER REMOVAL".
3. If the dimension is greater than 3-1/4", rotate the brake adjustment nut (A, Figure 33) clockwise to increase brake tension. If the dimension is less than 3", rotate the nut counter-clockwise to decrease brake tension.
4. Reinstall the belt cover and tighten the bolts securely.



WARNING



Once blade is disengaged it should come to a stop in 3 seconds or less. If the blade continues to rotate after 3 seconds the blade brake must be adjusted. DO NOT continue to operate the machine if the blade brake is not operating properly.

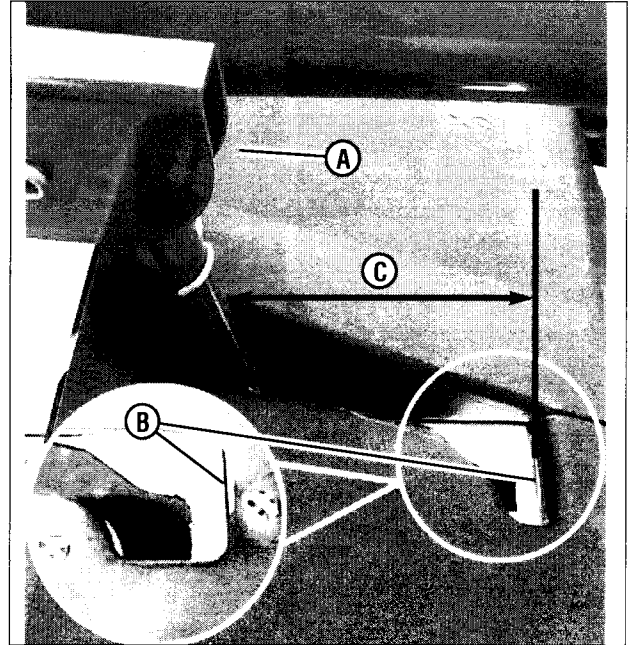

Figure 32: Measuring blade brake clearance

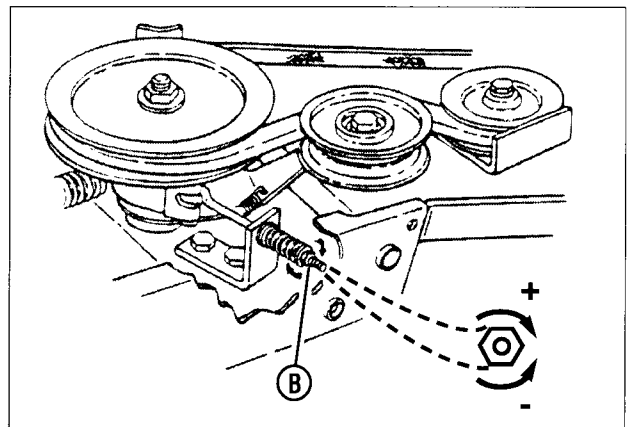

Figure 33: Adjusting blade brake tension

Maintenance (Continued)



WARNING



DO NOT attempt any adjustments, maintenance, service or repairs with the engine running. STOP engine. STOP blade. Engage parking brake. Remove key. Remove spark plug wire from spark plug and secure away from plug. Engine and components are HOT. Avoid serious burns, allow all parts to cool before working on machine. Fuel Filler Cap and vent must be closed securely to prevent fuel spillage.

Mower Deck Adjustment (Side-To-Side Levelness)

Before making deck leveling adjustments, check the tire pressure. Front tires 12 PSI, rear tires 12 PSI. If tires are properly inflated and mowing is still uneven, adjust side-to-side deck levelness.

1. Place the Rider on a smooth level surface.
2. Turn the engine off and remove the key. Remove the spark plug wire from the spark plug and secure the wire away from the plug.
3. Place a piece of angle iron, pipe, or similar object under the rear center of the deck.
4. Remove the rear hanger chains (**A, Figure 35**) and allow rear center of the deck to rest on the angle iron.
5. Measure the distance from the blade tips to the floor. If the measurement is within 1/8" from side-to-side, the deck attitude is satisfactory. If difference from side-to-side is greater than 1/8", continue with adjustment.
6. Loosen the hardware (**A, Figure 34**) that retains the left side of the blade pedal (**B**).
7. Move the lift arm (**C**) up or down as required until the blade tips are within 1/8" of each other.
8. Tighten the hardware loosened in Step 6. Recheck both sides of the deck for correct levelness.
9. Readjust the rear hanger chain pivots (**B, Figure 35**) to align with the holes in the support brackets (**D**).

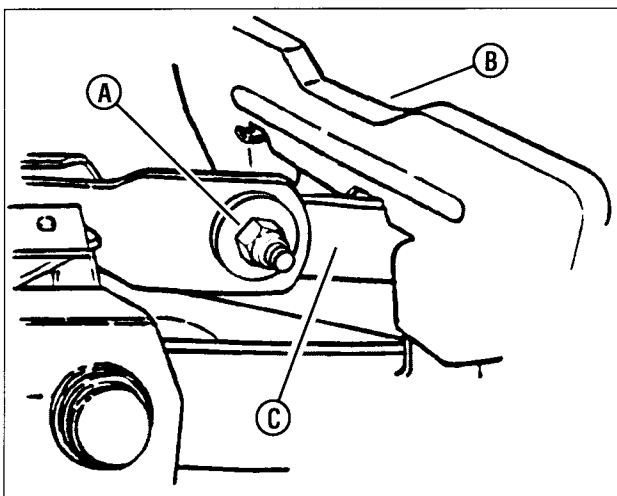

Figure 34: Adjusting deck levelness (side-to-side)
(View of left lift arm from right side of machine)

10. Remove the angle iron, pipe, or similar object, and proceed to check front to rear levelness.

Mower Deck Adjustment (Front-to-Rear Levelness)

28" and 33" Decks

With the Rear Engine Rider on a smooth, level surface, rotate the blade until the blade tips are at the front and rear of the deck. Measure the distance from the blade tips to the floor (**Figure 35**). The distance should be the same, or the rear 1/8" to 1/4" lower than the front. If the rear blade tip is higher than the front, or is more than 1/4" lower than the front, proceed with adjustment.

30" Decks

With the Rear Engine Rider on a smooth, level surface, rotate the blade until the blade tips are at the front and rear of the deck. Measure the distance from the blade tips to the floor (**Figure 35**). The distance should be the same, or the rear 1/8" to 1/4" higher than the front. If the rear blade tip is lower than the front, or is more than 1/4" higher than the front, proceed with adjustment.

Adjustment

1. Remove the rear hanger chains (**A, Figure 35**).
2. Turn each hanger pivot (**B**) the same number of rotations on the eye-bolt to raise or lower the rear of the deck.
3. Reinstall the rear hanger chains and measure the blade tips again.
4. Repeat Steps 1 through 3 until proper levelness is obtained.

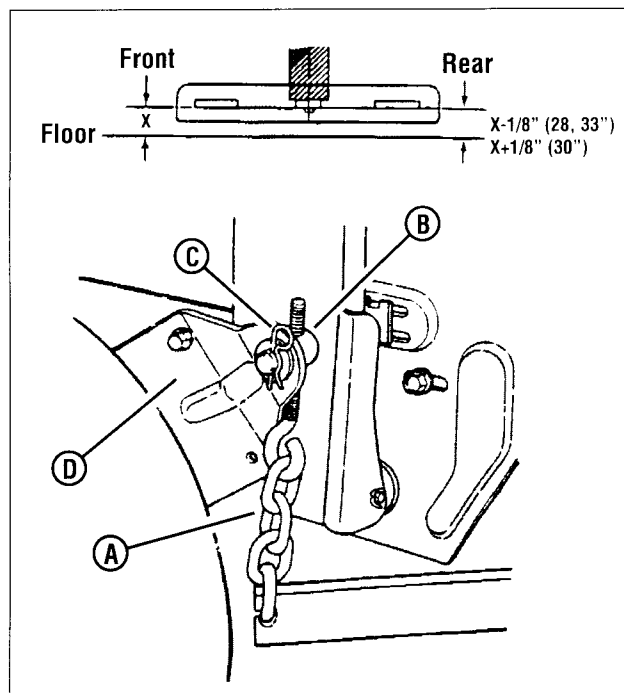

Figure 35: Adjusting the mower deck (front-to-rear)

Maintenance (Continued)



WARNING



DO NOT attempt any adjustments, maintenance, service or repairs with the engine running. STOP engine. STOP blade. Engage parking brake. Remove key. Remove spark plug wire from spark plug and secure away from plug. Engine and components are HOT. Avoid serious burns, allow all parts to cool before working on machine. Fuel Filler Cap and vent must be closed securely to prevent fuel spillage.

Mower Drive Belt Adjustment (For 28" & 30" Decks Only)

1. Remove the mower drive belt cover. Refer to the section entitled "CHECK MOWER DRIVE BELT".
2. Move the blade lever up and over to the "ON" position.
3. Place the deck cutting height lever in the third position (middle notch). Measure the belt spacing (**B, Figure 36**) between the idler pulley (**A**) and belt. The distance should measure 1-1/4" but no less than 1".

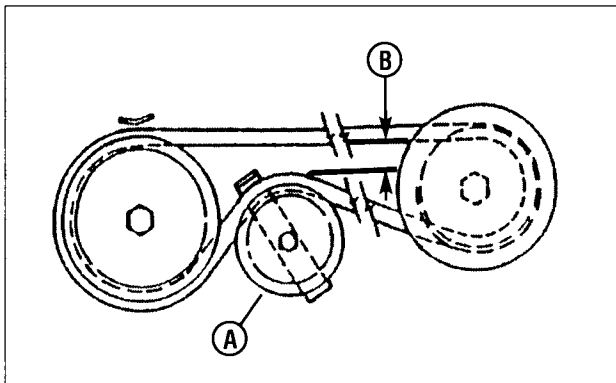

Figure 36: Measuring the belt spacing

4. If the distance is less than 1", adjust belt tension:
 - Move the blade lever to the "OFF" position.
 - Loosen the hardware (**A, Figure 37**) that secures the clamp that anchors the front frame assembly (**B**) to the rear main case.
 - Pull the front frame forward until the belt spacing, with the blade lever "ON", measures 1-1/4".
 - Retighten the hardware that secures the clamp. Make sure the hardware is tightened securely.

IMPORTANT: The SNAPPER Rear Engine Rider Models with 33" decks do not require belt tension adjustment. But, if the front frame assembly clamp is loosened for any reason, recheck the belt spacing between the idler pulley and belt. With the blade lever in the "ON" position, the distance should measure 1-3/4".

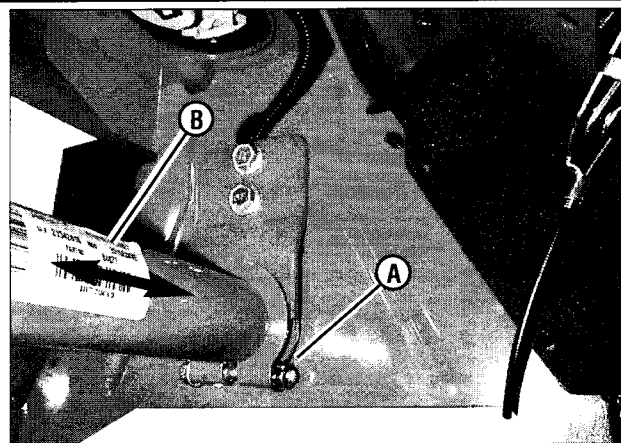

Figure 37: Mower belt adjustment

5. When belt adjustment is complete, it will be necessary to check Clutch/Brake Cable slack. Disengage the parking brake and allow the pedal (**A, Figure 38**) to remain in the engaged wheel drive (Up) position. The clutch/brake cable should have approximately 3/16" of slack. If the cable does not have slack adjustment of cable must be performed:

- Peel back the rubber clutch/brake pedal pad and push one ferrule (**B**) through the hole (**C**) in the pedal to attain slack in the cable.
- Recheck the cable for the approximate 3/16" of slack. Replace the pedal pad when adjustment is complete.

IMPORTANT: Too much slack may cause improper clutching, and braking could be affected. Too little slack may cause improper clutch function. Recheck the service brake/park brake and readjust if necessary. Refer to the section entitled "SERVICE BRAKE/PARK BRAKE ADJUSTMENT".

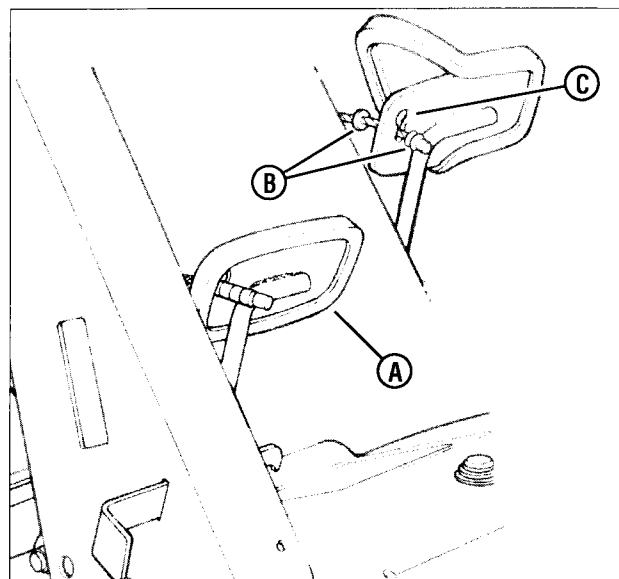

Figure 38: Clutch/brake cable adjustment

Maintenance (Continued)



WARNING



DO NOT attempt any adjustments, maintenance, service or repairs with the engine running. STOP engine. STOP blade. Engage parking brake. Remove key. Remove spark plug wire from spark plug and secure away from plug. Engine and components are HOT. Avoid serious burns, allow all parts to cool before working on machine. Fuel Filler Cap and vent must be closed securely to prevent fuel spillage.

Rear Engine Rider Drive Components

Your Snapper rider is equipped with a patented smooth start clutch. The clutch should operate smoothly and provide ample traction. If problems are experienced, contact your Snapper dealer for repair.

Service Brake / Park Brake Adjustment

Test the wheel brake on a dry concrete surface. When properly adjusted, the Rear Engine Rider will stop within 5 feet from fastest speed. If stopping distance is more than 5 feet, the wheel brake should be adjusted as follows:

1. Follow the WARNING statement found on this page.
2. Check the fuel level in tank. If over 3/4 full, remove tank. Refer to the section entitled "REMOVING THE FUEL TANK". If 3/4 or less, proceed to the next step.
3. Carefully stand the Rear Engine Rider on its rear bumper.
4. Depress the clutch/brake pedal (A, Figure 39) all the way down. Move and hold the park brake lever (B) in the "ON" position and release the clutch/brake pedal to set the park brake.

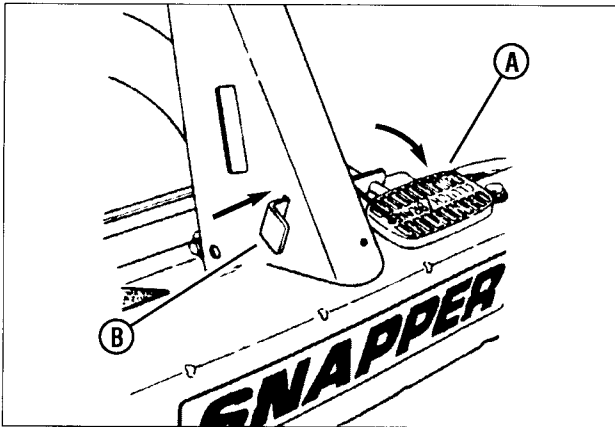

Figure 39: Setting the park brake

5. Measure the distance (A, Figure 40) between the end of the clutch/brake cable (B) and the bottom of the housing (C). The measurement should be 3/4".

NOTE: The cotter pin, brake spring, and clutch yoke (D, E, and F, Figure 40) are noted for reference purposes only.

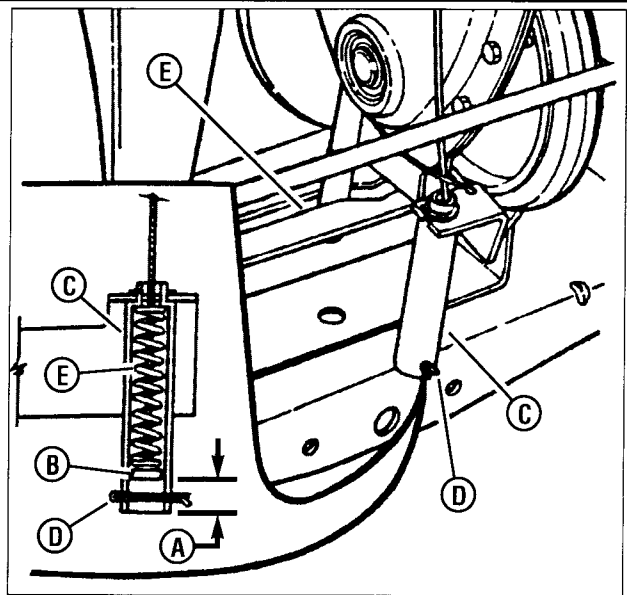

Figure 40: Adjusting the brake cable

6. If the measurement is not 3/4", loosen the two jam-nuts (A, Figure 41). Hold the clutch/brake cable (B) to the chain case bracket.
7. Adjust the cable up or down using the jam-nuts to obtain a distance of 3/4" between the end of the clutch/brake cable (adjustment shown in inset of Figure, 40) and the bottom of the housing.
8. After adjustment is complete, securely tighten the cable jam-nuts.
9. Retest the wheel brake.

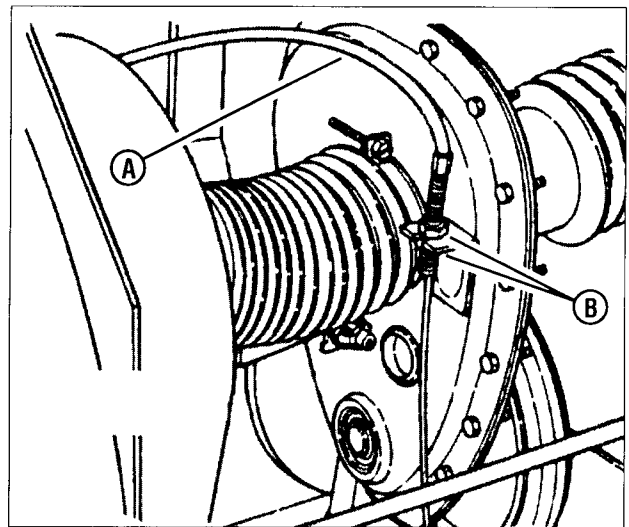

Figure 41: Brake cable adjusting nuts

Maintenance (Continued)



WARNING



DO NOT attempt any adjustments, maintenance, service or repairs with the engine running. STOP engine. STOP blade. Engage parking brake. Remove key. Remove spark plug wire from spark plug and secure away from plug. Engine and components are HOT. Avoid serious burns, allow all parts to cool before working on machine. Fuel Filler Cap and vent must be closed securely to prevent fuel spillage.

Mower Blade Replacement

Blade Wear Limits

1. Inspect the blade frequently for signs of excessive wear or damage (**Figure 42**):
 - (A) New blade;
 - (B) Wear limit (notch starts);
 - (C) Dangerous condition - do not use on mower! Replace with new blade.

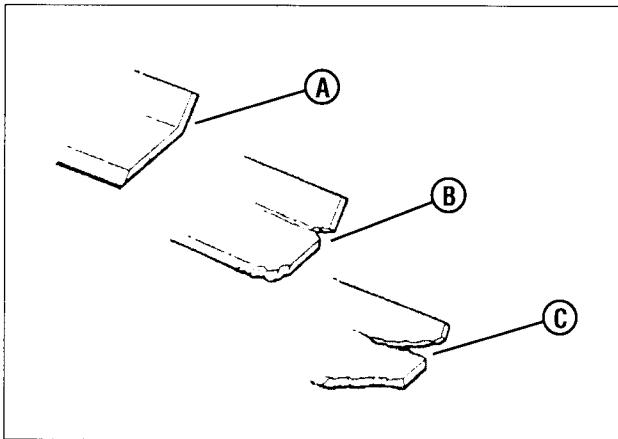

Figure 42: Mower blade wear limits



WARNING



Wear heavy leather gloves when handling or working around cutting blades. Blades are extremely sharp and can cause severe injury. DO NOT use a cutting blade that shows signs of excessive wear or damage.

Blade Sharpening

1. Follow the WARNING statement found on this page.
2. Check the fuel level in the tank. If over 3/4 full, remove the tank. Refer to the section entitled "REMOVING FUEL TANK". If 3/4 or less, proceed to the next step.
3. Carefully stand the Rear Engine Rider on its rear bumper.

4. Remove the bolts (**B, Figure 43**), washers (**C**) and nuts (**D**) securing the mower blade (**A**) to the spindle.
5. Inspect the condition of the blade (**Figure 42**).
6. If the blade is in good condition, sharpen at 22 to 28 degrees (**B, Figure 44**). DO NOT sharpen beyond existing cutting edge (**A**).
7. Check blade balance after sharpening. If necessary, correct blade balance by grinding the heavy end of the blade.
8. Reinstall the blade. Torque the blade mounting bolts to the recommended range of 30 to 40 ft. lbs.

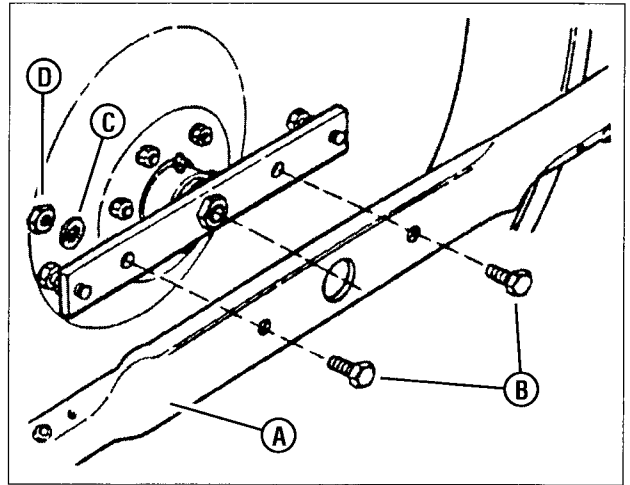

Figure 43: Removing the mower blade

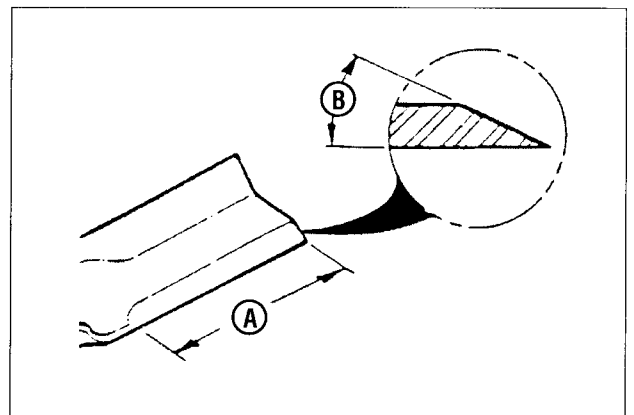

Figure 44: Sharpening the mower blade

Maintenance (Continued)



WARNING



DO NOT attempt any adjustments, maintenance, service or repairs with the engine running. STOP engine. STOP blade. Engage parking brake. Remove key. Remove spark plug wire from spark plug and secure away from plug. Engine and components are HOT. Avoid serious burns, allow all parts to cool before working on machine. Fuel Filler Cap and vent must be closed securely to prevent fuel spillage.

Mower Drive Belt Replacement

Inspect the mower drive belt as described in the section, "CHECK MOWER DRIVE BELT". Replace the belt if signs of excessive wear and/or damage are present.

Belt Removal

1. Remove the mower drive belt cover. Refer to the section entitled "DRIVE BELT COVER REMOVAL".
2. Remove the old belt.

Belt Replacement

1. Follow the WARNING statement found on this page.
2. Check the fuel level in the tank. If over 3/4 full, remove the tank. Refer to the section entitled, "REMOVING FUEL TANK". If 3/4 or less, proceed to the next step.
3. Carefully stand the Rear Engine Rider on its rear bumper.
4. Route the new belt through the engine belt guide (B, Figure 45) up to the engine pulley (A).

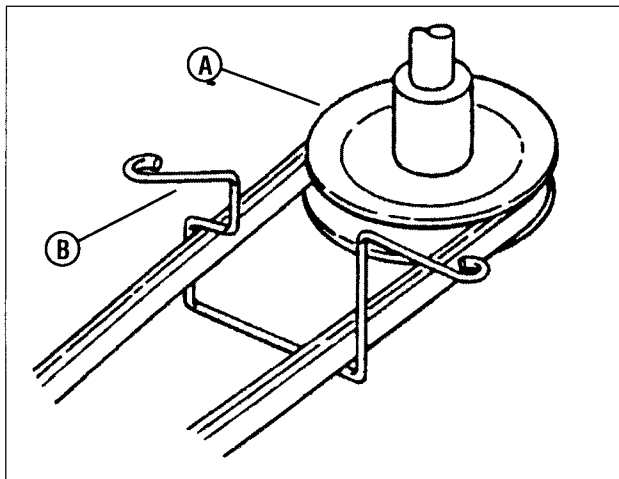

Figure 45: Engine pulley and belt guide

5. Move the transmission shift lever to the neutral (N) position.
6. Rotate the clutch yoke (F, Figure 40) out with your hand and work the belt between the drive disc and the rubber driven disc.
7. To clear the primary chain case, move the transmission shift lever to the #5 position. Route the belt around the drive disc and into the drive pulley belt groove.

8. Remove the idler (A, Figures 46 and 47).
9. Route the belt onto the spindle pulley (C). Make sure the belt is inside the spindle belt guide (D) and the idler belt guide (B). Route the belt as shown.
10. Reinstall the idler removed in Step 8. The idler belt guide tab should be positioned in the hole located on the idler arm. Tighten the idler pulley bolt securely.
11. Adjust the belt guide to allow 1/16" belt-to-belt guide clearance (E).
12. Check the mower drive belt tension and adjust if necessary (28" & 30" decks only). Refer to the Section entitled "MOWER DRIVE BELT ADJUSTMENT".
13. Reinstall the mower drive belt cover.

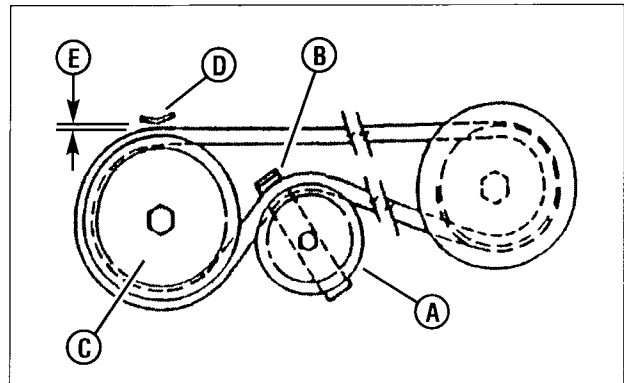

Figure 46: Belt routing for 28 and 30 inch decks

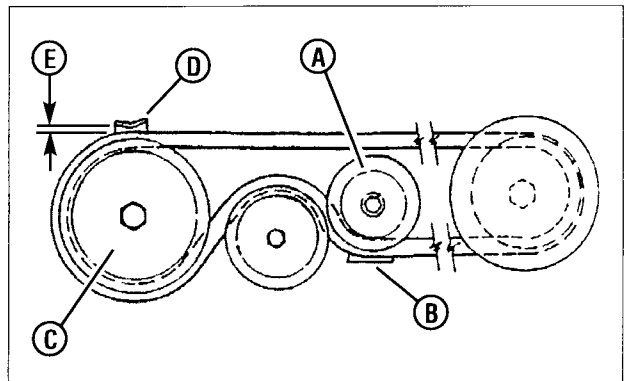

Figure 47: Belt routing for 33 inch decks

Maintenance (Continued)



WARNING



DO NOT attempt any adjustments, maintenance, service or repairs with the engine running. Stop engine. Stop blade. Engage parking brake. Remove key. Remove spark plug wire from spark plug and secure away from plug. Engine and components are HOT. Avoid serious burns, allow all parts to cool before working on machine. Fuel Filler Cap and Vent must be closed securely to prevent fuel spillage. DO NOT attempt to service or charge the battery while it is installed on the machine.

Battery

Battery Removal

1. Carefully pull each side of the battery cover (**A, Figure 48**) away from the ratchet fasteners (**B**) and remove the cover.

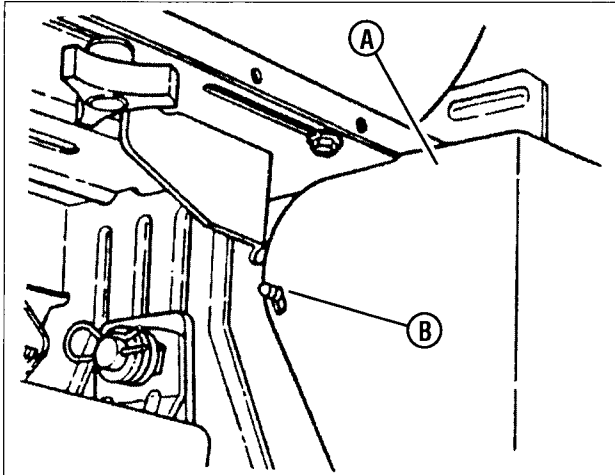

Figure 48: Removing the battery cover

2. Remove the hair pin and swivel from the deck support to allow clearance for battery removal.
3. Slide the battery from the battery box to gain access to the terminal cables.
4. Observe and note the cable positions (**A and B, Figure 49**) on the battery.
5. Disconnect the cables from the battery terminals, disconnecting BLACK (Negative) cable (**A**) first. Retain the mounting bolts and nuts.



CAUTION



If the battery is removed, DO NOT operate the engine without insulating the Positive (+) battery cable terminal with electrical tape, or sparking from the battery cables can result.

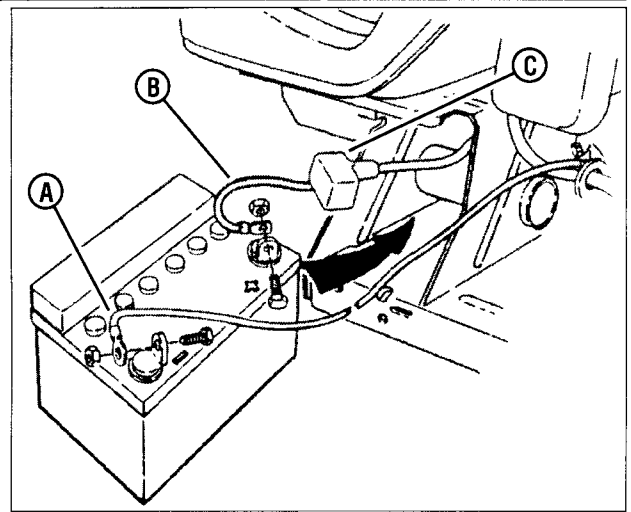

Figure 49: Connecting the battery



WARNING



The cables must be connected to the battery terminals in the proper position as shown. DO NOT attempt to charge the battery while installed on the Rear Engine Rider. DO NOT use "BOOST" chargers on the battery.

Battery Installation

1. Slide the battery partially into the battery housing.
2. Connect the red positive (+) cable (**B, Figure 49**) first, from the wiring harness to the positive terminal (+) on the battery, using the bolt and nut provided in the hardware bag. Connect the black negative (-) cable (**A**) last, to the negative terminal (-) on the battery, using the bolt and nut. Apply a small amount of grease over the terminals to prevent corrosion.
3. Reinstall the positive terminal insulator (**C**).
4. Insert the battery completely into the battery housing.
5. Reinstall the battery cover (**A, Figure 48**).
6. Reinstall the swivel and hair pin for the deck support.

Maintenance (Continued)



WARNING



The electrolyte (acid) produces a highly explosive gas. Keep all sparks, flame and fire away from area when charging battery or when handling electrolyte or battery. Electrolyte (acid) is a highly corrosive liquid. Wear eye protection. Wash affected areas immediately after having eye or skin contact with electrolyte (acid). Battery acid is corrosive. Rinse empty acid containers with water and mutilate before discarding. If acid is spilled on battery, bench, or clothing, etc., Flush with clear water and neutralize with baking soda. DO NOT attempt to charge battery while installed on the rider. DO NOT use "BOOST" chargers on the battery.

Battery Service

1. Remove the battery. Refer to the section entitled "BATTERY REMOVAL".
2. Place the battery in a well ventilated area on a level surface.
3. Using distilled water, refill the cells as required to cover the cell plates (of which can also be viewed through the plastic battery case).
4. With the cell caps removed, connect the battery charger to the battery terminals. Red to positive (+) terminal and black to negative (-) terminal.
5. Slow charge the battery at 1 amp for 10 hours.
6. If the battery will not accept a charge or is partially charged after 10 hours of charging at 1 amp, replace with a new battery.

Battery Storage

If the mower is to be stored out of season on its rear bumper, it is recommended the battery be removed, charged and stored.

1. Remove the battery. Refer to the section entitled "BATTERY REMOVAL".
2. Perform battery service.
3. Bring the battery to full charge, if required.
4. Store the battery in an area away from the rider on a wood surface. DO NOT STORE THE BATTERY ON A CONCRETE SURFACE.

New Battery Preparation

1. Remove the battery from the carton.
2. Place the battery in a well ventilated area on a level non-concrete surface.
3. Remove the battery cell caps. Fill the cells as required with electrolyte (purchased separately) to the proper level. Filling the battery with electrolyte will bring the battery to 80% charged state.
4. With the cell caps removed, connect the battery charger to the battery terminals; RED to positive (+) and BLACK to negative (-) terminal.



WARNING



DO NOT attempt to charge the battery while installed on the rider. DO NOT use "BOOST" chargers on the battery. DO NOT OVERFILL!

IMPORTANT: Never place anything in the battery other than the specified electrolyte.

5. Slow charge the battery at 1 amp for 2 hours to bring the battery to full charge.
6. After charging, check the level of electrolyte and add as needed to bring the level to 3/16" above the cell plates.
7. Reinstall the cell caps.
8. Remove the hair pin and swivel from the deck support to allow clearance for battery installation.
9. Slide the battery partially into the battery housing.
10. Connect the red positive (+) cable (**B, Figure 49**) first, from the wiring harness to the positive terminal (+) on the battery, using the bolt and nut provided in the hardware bag. Connect the black negative (-) cable (**A**) last, to the negative terminal (-) on the battery, using the bolt and nut. Apply a small amount of grease over the terminals to prevent corrosion.
11. Insert the battery completely into the battery housing.
12. Reinstall the battery cover (**A, Figure 48**).
13. Reinstall the swivel and hair pin for the deck support.

Battery Testing

There are two types of battery tests: Unloaded and Loaded. The unloaded test is the procedure that will be discussed. It's the simplest and most commonly used. An unloaded test is made on a battery without discharging current. To perform unloaded testing, check charge condition using either a hydrometer or voltmeter.

1. Using a voltmeter, voltage readings appear instantly to show the state of charge. Remember to hook the positive lead to the battery's positive terminal, and the negative lead to the negative terminal.
2. A hydrometer measures the specific gravity of each cell. The specific gravity tells the degree of charge; generally, a specific gravity of about 1.265 to 1.280 indicates full charge. A reading of 1.230 to 1.260 indicates the battery should be charged. The chart on the next page shows the charge level as measured by syringe float hydrometer, digital voltmeter and five ball hydrometer.



WARNING



Shield the positive terminal with the terminal cover located on the battery harness. This prevents metal from touching the positive terminal, which could cause sparks.

Maintenance (Continued)



Battery Testing (Continued)

State of Charge	Battery Condition Chart		
	Syringe Hydrometer	Digital Voltmeter	Five Ball Hydrometer
100% Charged w/ Sulfate Stop	1.280	12.80v	Five Balls Floating
100% Charged	1.265	12.60v	Four Balls Floating
75% Charged	1.210	12.40v	Three Balls Floating
50% Charged	1.160	12.10v	Two Balls Floating
25% Charged	1.120	11.90v	One Ball Floating
0% Charged	Less than 1.100	Less than 11.80v	Zero Balls Floating

Snapper Rear Engine Rider Accessories

Part No.	Description of Kit	Models Used on
7060517	Wheel Weight (8" Wheels)	All Rear Engine Riders
7060601	Smooth Start Clutch	All Rear Engine Riders
7060697	Dump Cart	All Rear Engine Riders
7061400	Gauge Wheel	All 33" Deck Rear Engine Riders
7060794	Gauge Wheel	All 41" & 42" Deck Rear Engine Riders
7060941	Single Bag Catcher *	All 25" Deck Rear Engine Riders
7060942	Single Bag Catcher *	All 26" & 30" Deck Rear Engine Riders
7060943	Single Bag Catcher *	All 28" & 33" Deck Rear Engine Riders
7060944	Single Bag Catcher *	All 41" & 42" Deck Rear Engine Riders
7060945	Twin Bag Catcher *	All 41" & 42" Deck Rear Engine Riders
7060946	Twin Bag Catcher *	All 28" & 33" Deck Rear Engine Riders
7060947	Bag-N-Wagon *	All 28" & 33" Deck Rear Engine Riders
7060948	Thatcherizer	All Series 7 & Newer Riders
7060964	Wagon Cover	All 28" & 33" Deck Rear Engine Riders
7061190	Weight (Front)	All Series 7 & Newer Riders
7060959	Dozer Blade (36" Blade)	All Rear Engine Riders
7060357	Tire Chains (Tires-16 x 6.50-8)	All Rear Engine Riders
7060358	Tire Chains (Tires-16 x 4.80-8)	All Rear Engine Riders
7061823	Ninja Recycling (Cover)	All 25" Deck Rear Engine Riders
7061049	Recycling (Cover)	All 25" Deck Rear Engine Riders
7061253	Ninja Recycling (Cover)	All 28" Deck Rear Engine Riders
7061254	Ninja Recycling (Cover)	All 30" Deck Rear Engine Riders
7061255	Ninja Recycling (Cover)	All 33" Deck Rear Engine Riders
7061987	Ninja Recycling (Cover)	All 41" & 42" Deck Rear Engine Riders
7061910	Utility Trailer	All Rear Engine Riders
7061911	Aerator	All Rear Engine Riders
7061912	Dethatcher	All Rear Engine Riders
7061913	Lawn Sweeper	All Rear Engine Riders
7061914	Dethatcher Kit	All Rear Engine Riders
7061915	Lawn Roller	All Rear Engine Riders
7061916	Broadcast Spreader	All Rear Engine Riders

Maintenance

* WARNING

Catcher bags used on SNAPPER products are made of woven fabric, and thus are subject to deterioration and wear during normal usage. Check condition of bags before each use. Immediately replace worn or damaged catcher bags with only bags recommended by SNAPPER.

Maintenance (Continued)

Service Schedule

ITEM	SERVICE PERFORMED	REF.	EACH USE	5 HRS	25 HRS	50 HRS	100 HRS	EACH SEASON
Engine Oil	Check Oil Level	Page 6	X					
	Initial Oil Change	Page 13		X				
	Periodic Oil Change	Page 15			X*			
Air Pre-Cleaner	Clean Sponge	Engine Manual			X**			
	Pre-cleaner Element				X**			
Air Cleaner	Replace Element	Engine Manual			X**			
Spark Plug	Replace	Engine Manual					X	
Fuel Filter	Replace	Page 18					X	
Engine Cooling System	Clean Shroud & Fins	Engine Manual					X**	
Battery	Check Electrolyte	Page 26			X			X
Battery	Charge	Pages 25, 26						X
Tires	Check Pressures	Page 6	X					
Drive Belts	Check for Wear and Tension	Pages 14, 24			X			X
Mower Blades	Check for wear, Damage & Replacement	Page 23			X			
Mower Deck	Clean Debris Accumulation	Page 6	X		X			X
Lubrication Points	Grease or Oil	Pages 15-17			X			X
Lubricate Chain Case and Transmission	Check Grease Level	Page 17					X	X
Blade Brake Stopping Time	Check Blade Stopping for Proper Operation	Pages 14, 19	X					X
Clutch/Brake System	Check Clutch/Brake for Proper Operation	Pages 14, 22	X					X
Reverse Lockout Mechanism	Check Function	Pages 6, 12, 15	X	X				

* Change oil every 25 hours when operating under heavy load or high temperatures.

** Clean more often under dusty conditions or when air debris is present.

Maintenance (Continued)

Maintenance/Replacement Parts

Engine Speed Control (Briggs Engine)	7022751
Engine Speed Control (Kohler Engine)	7074320
Engine Speed Control (Honda Engine)	7075089
Clutch/Brake Cable	7022449
Clutch/Brake Cable (33" Deck Models Only)	7074131
Brake Cable	7072648
28" Cutter Blade (Standard - Not Air Lift Compatible)	7035635
28" Cutter Blade (Standard - Air Lift Compatible)	7019515
28" Cutter Blade (Mulching)	7016980
28" Cutter Blade (Ninja - Quad Edge)	7026453
30" Cutter Blade (Standard - Not Air Lift Compatible)	N/A
30" Cutter Blade (Standard - Air Lift Compatible)	7018069
30" Cutter Blade (Ninja - Quad Edge)	7026565
33" Cutter Blade (Standard - Not Air Lift Compatible)	7034168
33" Cutter Blade (Standard - Air Lift Compatible)	7019523
33" Cutter Blade (Mulching)	7016982
33" Cutter Blade (Ninja - Quad Edge)	7024741
Air Lift Kit (28" and 33" Decks)	7060480
Air Lift Kit (30" Deck)	7060735
Engine to Cutting Deck Belt (28" and 30" Decks)	7022252
Engine to Cutting Deck Belt (33" Decks)	7043844
Rubber Drive Disc	7053103
Parts Manual for Rear Engine Rider Series 23	7006152
Parts Manual for Rear Engine Rider Series 23 (California Models)	7006265

Troubleshooting

PROBLEM	PROBABLE CAUSE	CORRECTIVE ACTION
Engine Will Not Start Using Recoil Starter	1. Fuel tank empty.	1. Fill fuel tank with fresh fuel to proper level.
	2. Engine needs choking.	2. Move choke control to "CHOKE" position.
	3. Spark plug wire disconnected.	3. Place spark plug wire onto spark plug.
	4. Faulty parking brake, blade or ignition switch.	4. Contact authorized SNAPPER dealer.
	5. Park brake not engaged.	5. Engage park brake.
	6. Ignition is in the OFF position.	6. Turn ignition switch to the RUN position.
Engine Will Not Start Using Electric Starter	1. Fuel tank empty.	1. Fill fuel tank with fresh fuel to proper level.
	2. Engine needs choking.	2. Move choke control to "CHOKE" position.
	3. Spark plug wire disconnected.	3. Place spark plug wire onto spark plug.
	4. Faulty parking brake, blade or ignition switch.	4. Contact authorized SNAPPER dealer.
	5. Park brake not engaged.	5. Engage park brake.
	6. Blown Fuse.	6. Replace with new 20 AMP fuse.
	7. Faulty interlock module.	7. Contact authorized SNAPPER dealer.
	8. Ignition is in the OFF position.	8. Turn ignition switch to the START position.
	9. Battery is weak or dead.	9. Charge or replace with new battery.
	10. Battery cables loose, broken disconnected or corroded.	10. Clean and connect battery cables. If broken, replace with new battery cables.
	11. Faulty electric starter or starter solenoid.	11. Contact authorized SNAPPER dealer.
	12. Starter cable loose, broken or disconnected.	12. Connect starter cable. If broken, replace with new starter cable.
	13. Electrical wiring harness disconnected or broken.	13. Connect or replace with new wiring harness.
Engine Stalls After Running	1. Operator not in seat.	1. Sit in operator's seat.
	2. Choke control in the "CHOKE" position.	2. Move choke control to "OFF" position.
	3. Fuel tank empty.	3. Fill fuel tank with fresh fuel to proper level.
	4. Engine air pre-cleaner and or air cleaner dirty.	4. Clean free of all debris.
	5. Spark plug defective or gap set improperly.	5. Service spark plug.
	6. Fuel filter restricted.	6. Replace fuel filter.
	7. Water, debris or stale fuel in fuel system.	7. Drain and clean fuel system.
Engine Loses Power	1. Excessive load on engine.	1. Lessen load.
	2. Engine air pre-cleaner or air cleaner dirty.	2. Clean or replace filters.
	3. Spark plug faulty.	3. Service spark plug.
	4. Water, debris or stale fuel in fuel system.	4. Drain and clean fuel system. Replace filter.
	5. Debris build up on engine cooling screen.	5. Clean all debris from engine cooling screen.
Engine Backfires When Turned To "STOP"	1. Throttle control set too "FAST".	1. Set throttle control to "SLOW" and allow engine to idle. Then, turn key to "OFF".
Excessive Vibration	1. Damaged, out of balance or bent mower blades.	1. Service mower blade(s).
	2. Loose blade components.	2. Service and tighten loose parts.
	3. Loose or missing air lift (if equipped).	3. Replace air lifts. Tighten to proper torque.
	4. Lumpy or frayed belt.	4. Replace belt.
	5. Bent Idler, stationary or spindle pulley.	5. Replace pulley.

Troubleshooting (Continued)

PROBLEM	PROBABLE CAUSE	CORRECTIVE ACTION
Rider Will Not Move Or Loss of Traction	1. Drive disc worn or damaged.	1. Replace drive disc.
	2. Rubber drive disc is not tracking properly on drive disc.	2. Adjust rubber drive disc.
	3. Tapered axle bolt and nut missing.	3. Replace with SNAPPER tapered bolt & nut.
	4. Axle bearing seized.	4. Contact authorized SNAPPER dealer.
	5. Insufficient lubrication in chain case or transmission/differential.	5. Contact authorized SNAPPER dealer.
Blade(s) Not Cutting	1. Blade engagement lever in the "OFF" position.	1. Move lever to the "ON" position.
	2. Mower belt slipping.	2. Adjust or replace mower belt.
	3. Cutting blade is dull, worn or damaged.	3. Sharpen or replace cutting blade.
Cutting Grass Improperly	1. Uneven tire pressure.	1. Bring to proper pressure. 12 PSI front tire & 12 PSI rear tire.
	2. Cutting height too low or high.	2. Adjust cutting height.
	3. Engine speed too slow.	3. Move throttle control to "FAST" position.
	4. Forward speed too fast.	4. Move transmission shift lever to a slower speed.
	5. Terraced cut, side to side.	5. Adjust side to side level.
	6. Excessive deck pitch, front to rear.	6. Adjust front to rear pitch.
	7. Cutting blade(s) dull or damaged.	7. Sharpen cutting edges or replace blade(s).
	8. Mower belt slipping.	8. Adjust tension or replace mower belt.
Poor Grass Discharge	1. Engine speed too slow.	1. Move throttle control to "FAST" position.
	2. Forward speed too fast.	2. Move transmission shift lever to a slower speed.
	3. Grass is wet.	3. Mow when grass is dry.
	4. Excessively dull, worn or damaged blade(s).	4. Service mower blade.
	5. Build up of grass clippings and debris under deck.	5. Clean the underside of deck.
	6. Improper blade installed on deck.	6. Install proper SNAPPER blades.
Oil Leaking	1. Leaking chain case or differential plugs.	1. Verify plugs are not cracked & are in good shape. Check gaskets.
	2. Leaking engine block.	2. Contact authorized SNAPPER dealer.

SNAPPER®

2 YEAR LIMITED WARRANTY

For two (2) years from purchase date for the original purchaser's residential, non-commercial use, SNAPPER, through any authorized SNAPPER dealer will replace, free of charge (except for taxes where applicable), any part or parts found upon examination by the factory at McDonough, Georgia, to be defective in material or workmanship or both.

For ninety (90) days from purchase date for the original purchaser's commercial, rental, or other non-residential use, SNAPPER, through any authorized SNAPPER dealer will replace, free of charge, any part or parts found upon examination by the factory at McDonough, Georgia, to be defective in material or workmanship or both.

All transportation costs incurred by the purchaser in submitting material to an authorized SNAPPER dealer for replacement under this warranty must be paid by the purchaser.

This warranty does not apply to certain transmissions, to engines and their components, and batteries, as these items are warranted separately. This warranty does not apply to parts that have been damaged by accident, alteration, abuse, improper lubrication, normal wear, or other cause beyond the control of SNAPPER. This warranty does not cover any machine or component part that has been altered or modified changing safety, performance, or durability.

Batteries have a one (1) year warranty period with free replacement if required for one (1) year from the original purchase date. SNAPPER will not be responsible for any installation cost incurred. The battery warranty only covers original equipment batteries and does not cover damage to the battery or machine caused by neglect or abuse, destruction by fire, explosion, freezing, overcharging, improper maintenance, or use of improper electrolyte.

There is no other express warranty.

DISCLAIMER OF WARRANTY

Implied warranties, including those of merchantability and fitness for a particular purpose, are limited to two (2) years from purchase date for the original purchaser's residential or other non-commercial use, and ninety (90) days from purchase for the original purchaser's commercial, rental or other non-residential use, and to the extent permitted by law, any and all implied warranties are excluded. This is the exclusive remedy. Liabilities for consequential damages, under any and all warranties are excluded.

Some states do not allow limitations on how long an implied warranty lasts, or do not allow the exclusion or limitation of incidental or consequential damages, so the above limitation or exclusion may not apply to you.

This warranty gives you specific legal rights, and you may also have other rights which vary from state to state.

WARNING: THE USE OF REPLACEMENT PARTS OTHER THAN GENUINE SNAPPER PARTS MAY IMPAIR THE SAFETY OF SNAPPER PRODUCTS AND WILL VOID ANY LIABILITY AND WARRANTY BY SNAPPER ASSOCIATED WITH THE USE OF SUCH PARTS.

IMPORTANT: Please fill out the attached SNAPPER Product Registration Card immediately and mail to:
Snapper's Product Registration Center, P.O. Box 1379, McDonough, Georgia 30253

SLOPE GUIDE

SIGHT AND HOLD THIS GUIDE LEVEL WITH A VERTICAL TREE, A CORNER OF A STRUCTURE, A POWER LINE POLE, OR A FENCE.

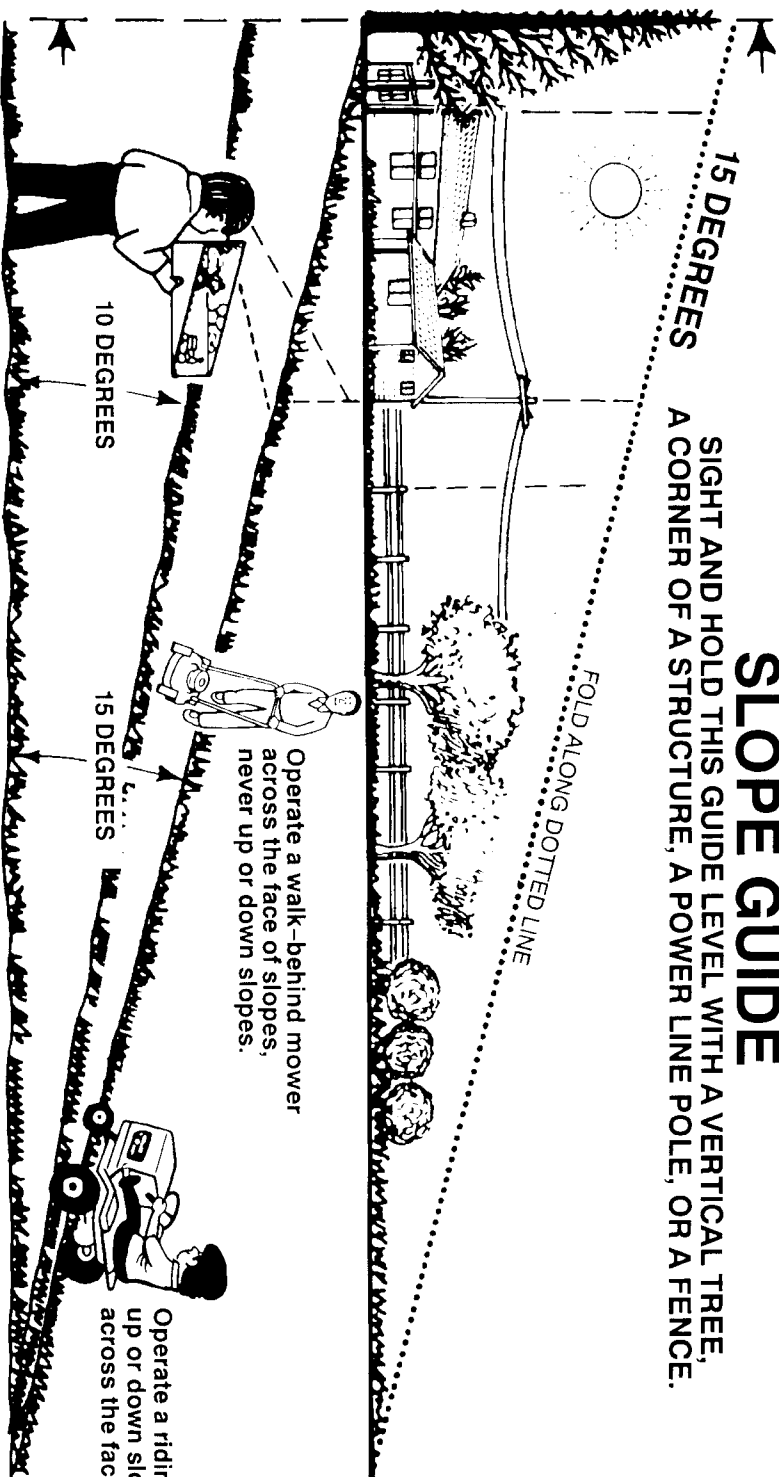

On a riding mower to determine if a slope is safe to mow: (1) disengage the blade(s), (2) put the unit in reverse, and (3) try to back straight up the slope. If you can back up the slope, it is generally safe to mow. However, if you do not feel safe, or if you are not completely sure, use this guide and do not mow a slope that is greater than 15 degrees. If the riding mower is used with a pull-behind or rear mounted attachment, do not operate the unit on a slope that is greater than 10 degrees.

A 15 degree slope is a hill that increases in height at approximately 2.5 feet in 10 feet.
A 10 degree slope is a hill that increases in height at approximately 1.7 feet in 10 feet.



Use extreme care at all times, and avoid sudden turns or maneuvers. Follow other instructions in this manual for safety in mowing on slopes. Operate a riding mower up or down slopes, never across the face of slopes. Operate a walk-behind mower across the face of slopes, never up or down slopes. Use extra care when operating on or near slopes and obstructions.

CUT HERE TO USE SLOPE GUIDE

SNAPPER®

REAR ENGINE RIDING MOWER SERIES 23

Product Specifications	2811523BV / C2811523BV	2812523BVE / C2812523BVE	3011523BV / C3011523BV	3012523BVE / C3012523BVE	3317523BVE / C3317523BVE
Deck Size (inches)	28	28	30	30	33
Height of Cut (inches)	1.5 - 4.0	1.5 - 4.0	1.5 - 4.0	1.5 - 4.0	1.5 - 4.0
Transmission Type	5-Spd Disc Drive	5-Spd Disc Drive	5-Spd Disc Drive	5-Spd Disc Drive	5-Spd Disc Drive
Ground Speed - Fwd/Rev (mph)	1.0 - 4.6 / 0 - 1.9	1.0 - 4.6 / 0 - 1.9	1.0 - 4.6 / 0 - 1.9	1.0 - 4.6 / 0 - 1.9	1.0 - 4.6 / 0 - 1.9
Engine Power (hp)	11.5	12.5	11.5	12.5	17.5
Engine Displacement (cc)	344	344	344	344	502
Fuel Tank Capacity (qt)	7	7	7	7	7

Common Service Parts

Part Number

Cutter Blade (28" Standard Air-Lift)	7019515
Cutter Blade (30" Standard Air-Lift)	7018069
Cutter Blade (33" Standard Air-Lift)	7019523
Cutting Deck Belt (28 and 30")	7022252
Cutting Deck Belt (33")	7043844
Parts Manual	7006152
Parts Manual (California Models)	7006265

Engine Power Rating Information: The gross power rating for individual gas engine models is labeled in accordance with SAE (Society of Automotive Engineers) code J1940 (Small Engine Power & Torque Rating Procedure), and rating performance has been obtained and corrected in accordance with SAE J1995 (Revision 2002-05). Torque values are derived at 3060 RPM; horsepower values are derived at 3600 RPM. Actual gross engine power will be lower and is affected by, among other things, ambient operating conditions and engine-to-engine variability. Given both the wide array of products on which engines are placed and the variety of environmental issues applicable to operating the equipment, the gas engine will not develop the rated gross power when used in a given piece of power equipment (actual "on-site" or net power). This difference is due to a variety of factors including, but not limited to, accessories (air cleaner, exhaust, charging, cooling, carburetor, fuel pump, etc.), application limitations, ambient operating conditions (temperature, humidity, altitude), and engine-to-engine variability. Due to manufacturing and capacity limitations, Briggs & Stratton may substitute an engine of higher rated power for this Series engine.